

DIMENSIONS

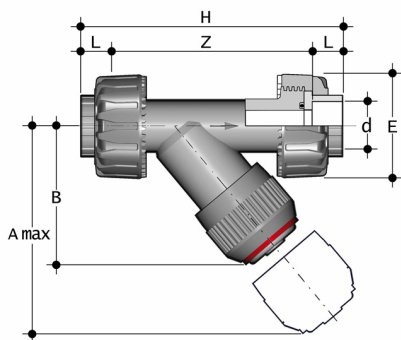

RVUIM

Sediment strainer with female union ends for socket welding, metric series

d	DN	PN	A max	B	E	H	Z	Fig.	g	EPDM code	FKM code
20	15	10	125	71	55	138	109	A	148	RVUIM020E	RVUIM020F
25	20	10	145	83	66	157	125	A	195	RVUIM025E	RVUIM025F
32	25	10	165	94	74	179	143	A	297	RVUIM032E	RVUIM032F
40	32	10	190	109	86	205	164	A	475	RVUIM040E	RVUIM040F
50	40	10	210	119	99	244	197	A	675	RVUIM050E	RVUIM050F
63	50	10	240	142,5	120	294	239	A	1100	RVUIM063E	RVUIM063F

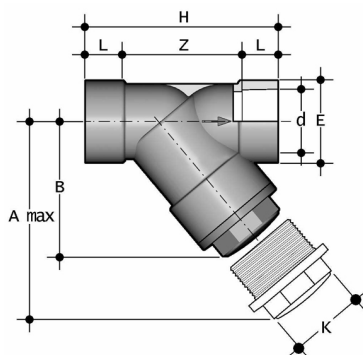

RVIM

Sediment strainer with female ends for socket welding, metric series

d	DN	PN	A max	B	E	H	K	Z	Fig.	g	EPDM code	FKM code
75	65	6	300	176	103	241	96	179	B	1580	RVIM075E	RVIM075F
90	80	4	325	193	115	260	105	189	B	1920	RVIM090E	RVIM090F
110	100	4	385	229	138	323	-	240	C	3000	RVIM110E	RVIM110F

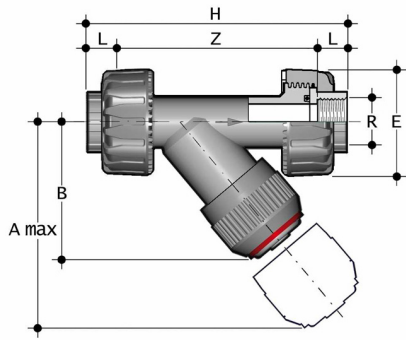

RVUFM

Sediment strainer with BSP threaded female union ends

R	DN	PN	A max	B	E	H	Z	Fig.	g	EPDM code	FKM code
1/2"	15	10	125	71	55	142	112	A	148	RVUFM012E	RVUFM012F
3/4"	20	10	145	83	66	159	126	A	195	RVUFM034E	RVUFM034F
1"	25	10	165	94	74	183	145	A	297	RVUFM100E	RVUFM100F
1" 1/4	32	10	190	109	86	214	171	A	475	RVUFM114E	RVUFM114F
1" 1/2	40	10	210	119	99	235	192	A	675	RVUFM112E	RVUFM112F
2"	50	10	240	143	120	285	234	A	1100	RVUFM200E	RVUFM200F

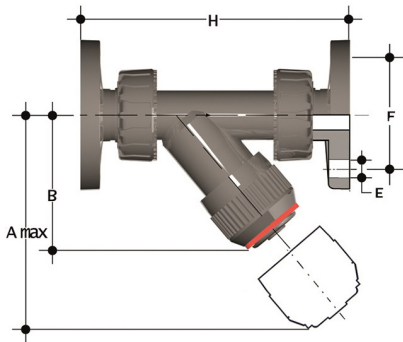

RVUOM

Sediment strainer with female union ends and fixed flanges, drilled EN/ISO/DIN PN10/16

d	DN	PN	A max	B	F	f	H	g	EPDM code	FKM code
20	15	10	125	72	65	14	163	248	RVUOM020E	RVUOM020F
25	20	10	145	84	75	14	193	295	RVUOM025E	RVUOM025F
32	25	10	165	95	85	14	211	397	RVUOM032E	RVUOM032F
40	32	10	190	111	100	18	244	625	RVUOM040E	RVUOM040F
50	40	10	210	120	110	18	277	825	RVUOM050E	RVUOM050F
63	50	10	240	139	125	18	331	1250	RVUOM063E	RVUOM063F

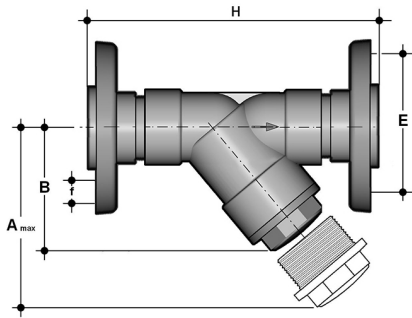

RVOM

Sediment strainer with steel core backing ring , PP/FRP coated, drilled EN/ISO/DIN PN10/16

d	DN	PN	A max	B	F	f	H	g	EPDM code	FKM code
75	65	6	300	176	145	18	356	5120	RVOM075E	RVOM075F
90	80	4	325	192	160	18	404	6020	RVOM090E	RVOM090F
110	100	4	385	231	180	18	475	7965	RVOM110E	RVOM110F

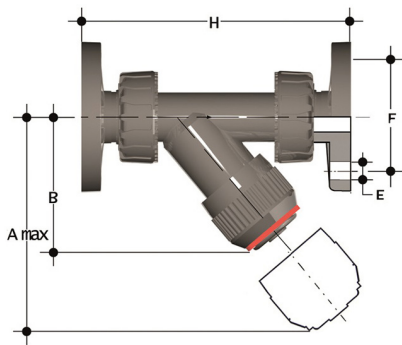

RVUOAM

Sediment strainer with female union ends and fixed flanges, drilled ANSI B16.5 cl.150 #FF

d	DN	PN	A max	B	F	f	H	g	EPDM code	FKM code
1/2"	15	10	125	72	60	16	175	248	RVUOAM012E	RVUOAM012F
3/4"	20	10	145	84	70	16	214	295	RVUOAM034E	RVUOAM034F
1"	25	10	165	95	79	16	237	397	RVUOAM100E	RVUOAM100F
1 1/4"	32	10	190	111	89	16	253	625	RVUOAM114E	RVUOAM114F
1 1/2"	40	10	210	120	98	16	289	825	RVUOAM112E	RVUOAM112F
2"	50	10	240	139	121	19	333	1250	RVUOAM200E	RVUOAM200F

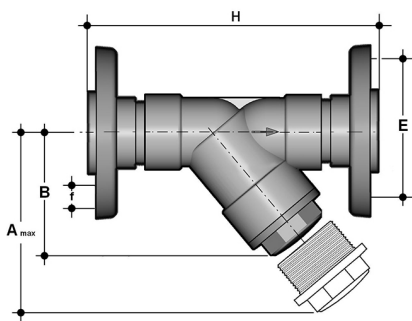

RVOAM

Sediment strainer with steel core backing ring , PP/FRP coated, drilled ANSI B16.5 cl.150 #FF

d - Size	DN	PN	A max	B	F	f	H	g	EPDM code	FKM code
75 - 2 1/2"	65	6	300	179	139,7	18	356	4725	RVOAM212E	RVOAM212F
90 - 3"	80	4	325	192	152,4	18	404	5175	RVOAM300E	RVOAM300F
110 - 4"	100	4	385	231	190,5	18	475	7405	RVOAM400E	RVOAM400F