

# DIMENSIONS

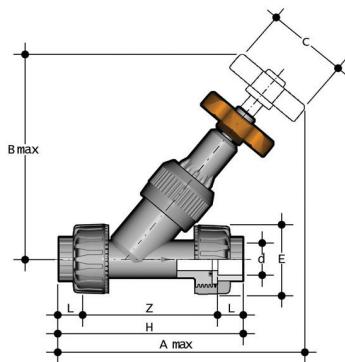

## VVUIV

Angle seat valve with female union ends for solvent welding, metric series

| d  | DN | PN | A max | B max | C   | E   | H   | L  | Z   | g    | EPDM+PE code |
|----|----|----|-------|-------|-----|-----|-----|----|-----|------|--------------|
| 16 | 10 | 16 | 170   | 124   | 60  | 55  | 135 | 14 | 107 | 238  | VVUIV016E    |
| 20 | 15 | 16 | 173   | 124   | 60  | 55  | 135 | 16 | 103 | 251  | VVUIV020E    |
| 25 | 20 | 16 | 197   | 146   | 60  | 66  | 158 | 19 | 120 | 413  | VVUIV025E    |
| 32 | 25 | 16 | 223   | 173   | 70  | 75  | 176 | 22 | 132 | 621  | VVUIV032E    |
| 40 | 32 | 16 | 258   | 195   | 85  | 87  | 207 | 26 | 155 | 903  | VVUIV040E    |
| 50 | 40 | 16 | 295   | 222   | 105 | 100 | 243 | 31 | 181 | 1320 | VVUIV050E    |
| 63 | 50 | 16 | 359   | 269   | 130 | 120 | 298 | 38 | 222 | 2238 | VVUIV063E    |

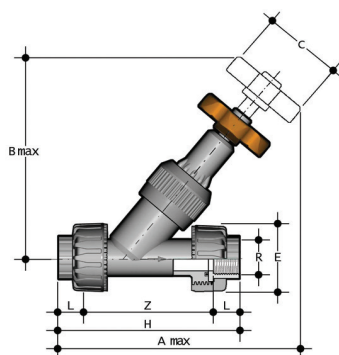

## VVUFV

Angle seat valve with BSP threaded female union ends

| R      | DN | PN | A max | B max | C   | E   | H   | L    | Z     | g    | EPDM+PE code |
|--------|----|----|-------|-------|-----|-----|-----|------|-------|------|--------------|
| 3/8"   | 10 | 16 | 170   | 124   | 60  | 55  | 135 | 11,4 | 112,2 | 238  | VVUFV038E    |
| 1/2"   | 15 | 16 | 173   | 124   | 60  | 55  | 143 | 15   | 113   | 251  | VVUFV012E    |
| 3/4"   | 20 | 16 | 197   | 146   | 60  | 66  | 160 | 16,3 | 127,4 | 413  | VVUFV034E    |
| 1"     | 25 | 16 | 223   | 173   | 70  | 75  | 183 | 19,1 | 144,8 | 621  | VVUFV100E    |
| 1 1/4" | 32 | 10 | 258   | 195   | 85  | 87  | 214 | 21,4 | 171,2 | 903  | VVUFV114E    |
| 1 1/2" | 40 | 10 | 295   | 222   | 105 | 100 | 235 | 21,4 | 192,2 | 1320 | VVUFV112E    |
| 2"     | 50 | 10 | 359   | 269   | 130 | 120 | 285 | 25,7 | 233,6 | 2238 | VVUFV200E    |

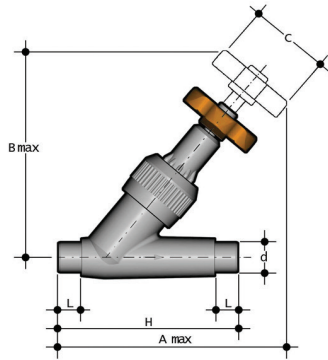

## VVDV

Angle seat valve with male ends for solvent welding, metric series

| d  | DN | PN | A max | B max | C   | H   | L  | g    | EPDM+PE code |
|----|----|----|-------|-------|-----|-----|----|------|--------------|
| 16 | 10 | 16 | 136   | 124   | 60  | 114 | 14 | 150  | VVDV016E     |
| 20 | 15 | 16 | 146   | 124   | 60  | 124 | 16 | 160  | VVDV020E     |
| 25 | 20 | 16 | 165   | 146   | 60  | 144 | 19 | 250  | VVDV025E     |
| 32 | 25 | 16 | 188   | 173   | 70  | 154 | 22 | 380  | VVDV032E     |
| 40 | 32 | 10 | 217   | 195   | 85  | 174 | 26 | 480  | VVDV040E     |
| 50 | 40 | 10 | 247   | 222   | 105 | 194 | 31 | 820  | VVDV050E     |
| 63 | 50 | 10 | 299   | 269   | 130 | 224 | 38 | 1345 | VVDV063E     |

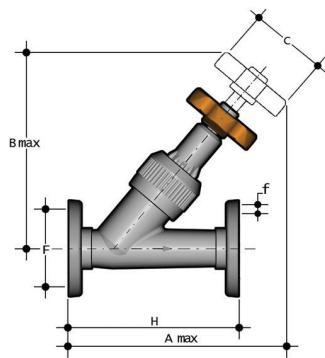

## VVOV

Angle seat valve with fixed flanges, drilled PN10/16

| d  | DN | PN | A max | B max | C   | F   | f  | H   | g    | EPDM+PE code |
|----|----|----|-------|-------|-----|-----|----|-----|------|--------------|
| 20 | 15 | 16 | 146   | 124   | 60  | 65  | 14 | 130 | 300  | VVOV020E     |
| 25 | 20 | 16 | 166   | 146   | 60  | 75  | 14 | 150 | 455  | VVOV025E     |
| 32 | 25 | 16 | 191   | 173   | 70  | 85  | 14 | 160 | 655  | VVOV032E     |
| 40 | 32 | 10 | 219   | 195   | 85  | 100 | 18 | 180 | 1025 | VVOV040E     |
| 50 | 40 | 10 | 249   | 222   | 105 | 110 | 18 | 200 | 1390 | VVOV050E     |
| 63 | 50 | 10 | 302   | 269   | 130 | 125 | 18 | 230 | 2155 | VVOV063E     |