



VKR/CE DN 10÷50

PVC-U/PP-H/PVDF

ELECTRICALLY ACTUATED TWO-WAY DUAL BLOCK®
REGULATING BALL VALVE



VKR/CE DN 10÷50

The VKR DUAL BLOCK® valve combines high reliability and safety aspects typical of VKD full bore ball valves with the new flow adjustment function with typical linear curve that meets the most stringent needs typical of industrial applications.



ELECTRICALLY ACTUATED TWO-WAY DUAL BLOCK® REGULATING BALL VALVE

- Joint system for solvent welding (PVC-U only), for welding (PP-H and PVDF only), for threading and flanging
- Patented **SEAT STOP®** ball carrier system that lets you micro-adjust ball seats and minimise the axial force effect.
- Easy radial disassembly allowing quick replacement of O-rings and ball seats without any need for tools
- **Radial dismounting valve body** (True Union) made for PVC-U, PVC-C and PVDF-H injection moulding equipped with built-in bores for actuation. ISO 9393 compliant test requisites
- Option of disassembling downstream pipes with the valve in the closed position
- High surface finish stem with double O-Ring and double groove ball connection
- **Integrated bracket** for valve anchoring
- Ball seat carrier can be adjusted using the **Easytorque adjustment kit**
- Actuation option: version with electric modulating actuator with 4-20 mA / 0-10 V inlet and 4-20 mA / 0-10 V outlet to monitor the position
- Valve suitable for carrying fluids that are clean and free of suspended particles.

Technical specifications - VKR	
Construction	2-way True Union ball valve with locked carrier and union nuts
Size range	DN 10 ÷ 50
Nominal pressure	PVC-U: PN 16 with water at 20° C PP-H: PN10 with water at 20° C PVDF: PN16 with water at 20° C
Temperature range	PVC-U: 0 °C ÷ 60 °C PP-H: 0° C ÷ 100° C PVDF: -40° C ÷ 140° C
PVC-U coupling standards	Solvent welding: EN ISO 1452, EN ISO 15493, BS 4346-1, DIN 8063, NF T54-028, ASTM D 2467, JIS K 6743. Can be coupled to pipes according to EN ISO 1452, EN ISO 15493, DIN 8062, NF T54-016, ASTM D 1785, JIS K 6741. Thread: ISO 228-1, DIN 2999, ASTM D 2464, JIS B 0203. Flanging system: ISO 7005-1, EN ISO 1452, EN ISO 15493 EN 588-1, DIN 2501, ANSI B.16.5 cl.150, JIS B 2220.
PP-H coupling standards	Welding: EN ISO 15494. Can be coupled to pipes according to EN ISO 15494 Thread: ISO 228-1, DIN 2999 Flanging system: ISO 7005-1, EN 1092-1, EN ISO 15494, EN 558-1, DIN 2501, ANSI B.16.5 cl.
PVDF coupling standards	Welding: EN ISO 10931 Can be coupled to pipes according to EN ISO 10931 Flanging system: ISO 7005-1, EN ISO 10931, EN 558-1, DIN 2501, ANSI B.16.5 cl. 150
Reference standards	PVC-U construction criteria: EN ISO 16135, EN ISO 1452, EN ISO 15493 PP-H construction criteria: EN ISO 16135, EN ISO 15494 PVDF construction criteria: EN ISO 16135, EN ISO 10931 Test methods and requirements: ISO 9393 PVC-U installation criteria: DVS 2204, DVS 2221, UNI 11242 PP-H installation criteria: DVS 2202-1, DVS 2207-11, DVS 2208-1, UNI 11318 PVDF installation criteria: DVS 2202-1, DVS 2207-15, DVS 2208-1 Actuator couplings: ISO 5211
Valve material	PVC-U / PP-H / PVDF
Seal material	EPDM, FKM (standard size O-Ring); PTFE (ball seats)
Control options	Electric actuator

In addition to the manually actuated version, VKR is also available in electrically actuated VKR/CE configuration. Actuators are firmly connected to the valve by the special FIP Power Quick modules fully made of PP-GR technopolymer. VKR/CE are constructed with actuators meeting current regulations and selected by FIP according to their quality and reliability requirements. The efficiency of these valves, tested according to the company's quality standards, is guaranteed by the expertise and know-how that FIP dedicates to manufacturing its products.

Technical specifications - Electric actuator	
Reference standards	<p>Construction criteria: Electromagnetic compatibility EMC 2004/108/CE. Low voltage directive 2006/95/CE. Machinery directive 2006/42/CE. R.O.H.S. directive 2011/65/CE</p> <p>Coupling for valves: ISO 5211; DIN 3337</p>
Actuator material	<p>Plastic parts: PA6,6 FV 30% and Nylon. Metallic parts: 304L stainless steel or steel + tin-plating</p>
Supply Voltage	<p>12-48V DC* - 24V AC/DC - 90-240V AC - 400V three-phase*</p> <p>*voltages available upon request</p>
Temperature range	<p>From -10 °C to +55 °C</p>
Standard equipment	<ul style="list-style-type: none"> • Manual safety override • Visual position indicator • Two auxiliary limit switches (5A) adjustable FC1, FC2 • Torque limiter • Positioner board 4-20 mA or 0-10V • Anti-condensation heating element
Accessories	<ul style="list-style-type: none"> • Fail Safe unit (NC or NO)
Special versions upon request	<ul style="list-style-type: none"> • Protection class IP68 or ATEX II 2 GD EEx d IIB T6
Electrical connection	<ul style="list-style-type: none"> • Power supply: DIN 43650 connector 3P + GND • Limit switch: Cable gland ISO M20

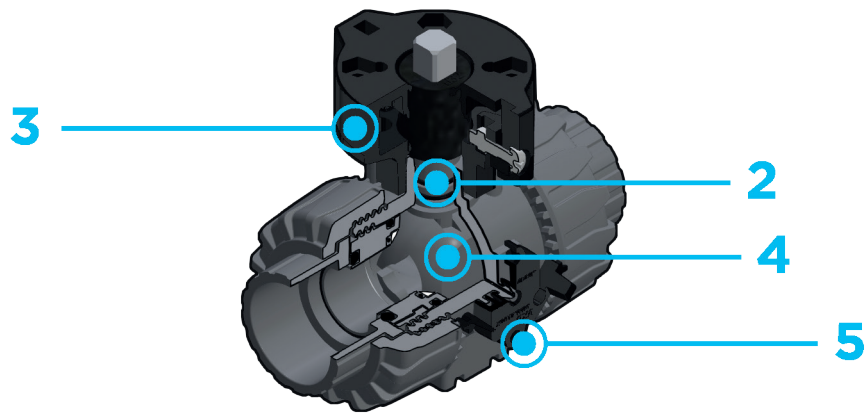
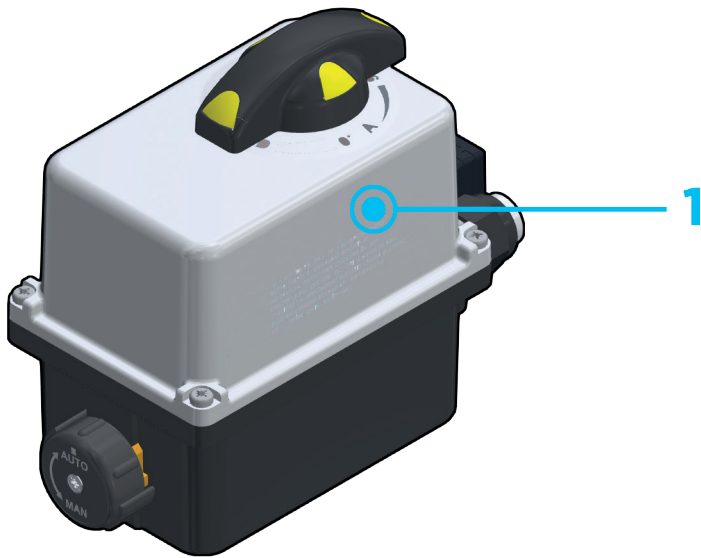

1 Electric modulating actuator constructed according to FIP specifications; with plastic shell and standard emergency override. Available with voltages from 12 to 240V with 4-20mA and 0-10V input.

2 High surface finish stem with double O-Ring. The double connection key system guarantees solid and reliable actuator torque transmission to the ball.

3 Easy to install **PowerQuick** module for pneumatic or electric actuator fully made of highly robust technopolymer.

4 The patented ball design provides linear flow regulation throughout its range of operation even when the valve is open just a few degrees and guarantees minimum pressure drops.

5 Patented **DUAL BLOCK®** system: prevents union nuts from loosening even under extreme operating conditions: e.g. vibration or thermal expansion.

TECHNICAL DATA

PRESSURE VARIATION ACCORDING TO TEMPERATURE

PVC-U BODY

For water and non-hazardous fluids with regard to which the material is classified as CHEMICALLY RESISTANT. In other cases, a reduction of the nominal pressure PN is required (25 years with safety factor).

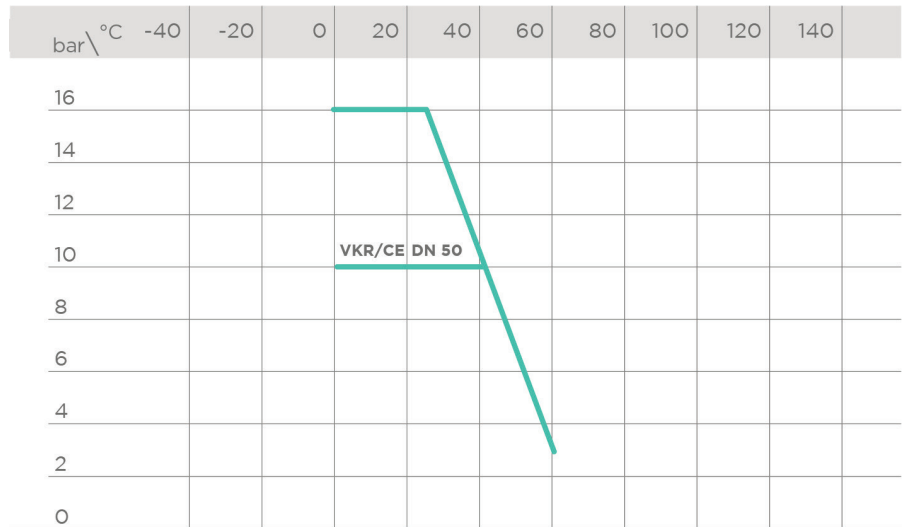

PP-H BODY

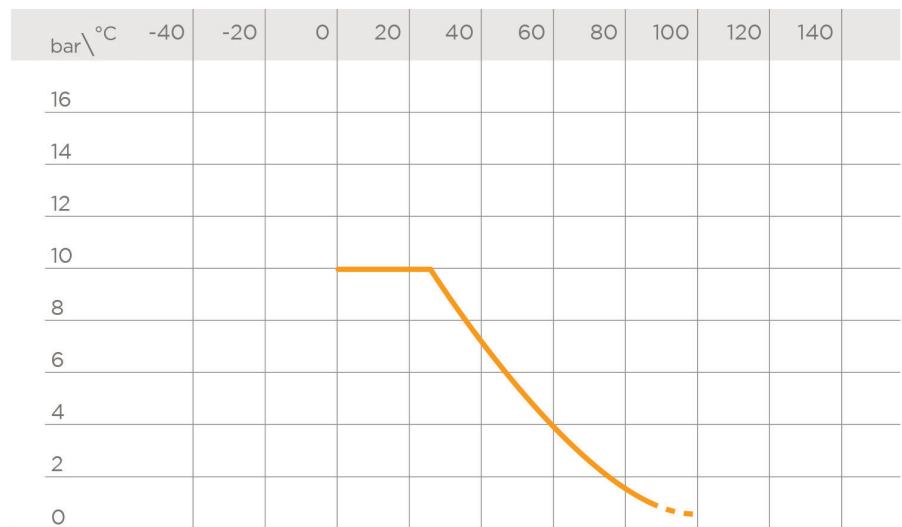

PVDF BODY

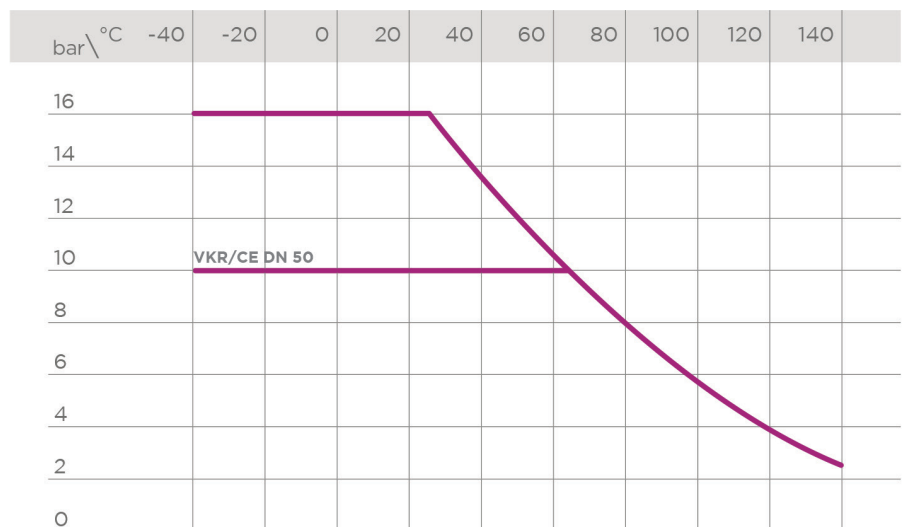

PRESSURE DROP GRAPH

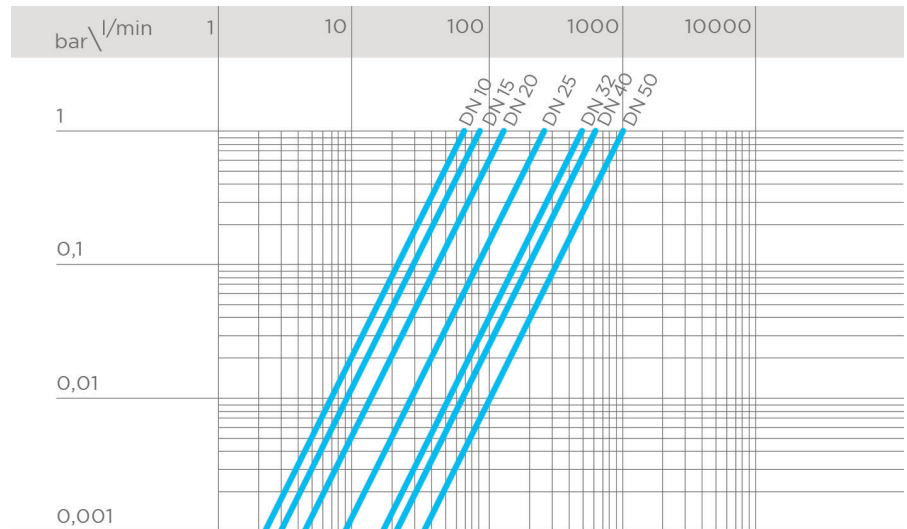

RELATIVE FLOW COEFFICIENT

The relative flow coefficient is the flow rate through the valve as a function of the degree of valve opening.
 X axis: Opening percentage of the ball
 Y axis: Relative flow coefficient

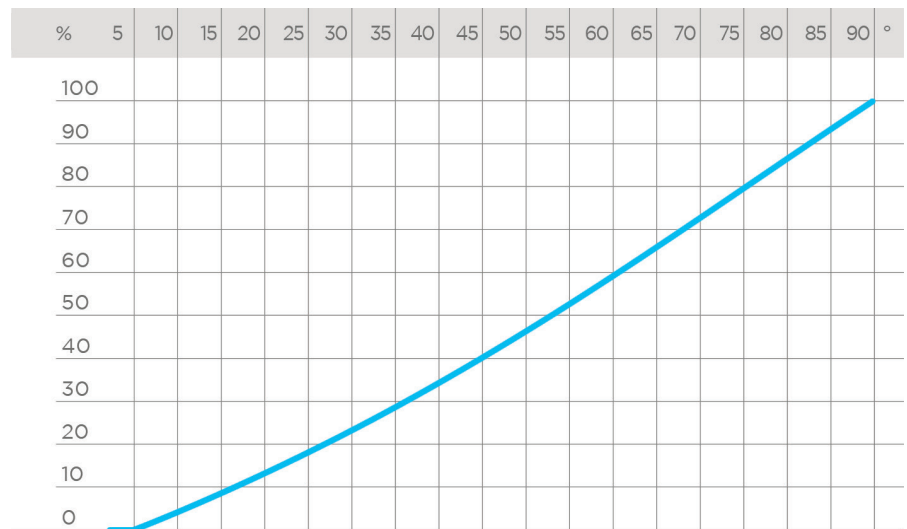

K_v100 FLOW COEFFICIENT

The K_v100 flow coefficient is the Q flow of litres per minute of water at a temperature of 20°C that will generate Δp= 1 bar pressure drop at a certain valve position.

The K_v100 values shown in the table are calculated with the valve completely open.

DN	10	15	20	25	32	40	50
K _v 100 l/min	83	88	135	256	478	592	1068

ELECTRIC ACTUATOR DATA

FUNCTIONAL CHARACTERISTICS

Characteristics	DC	AC/DC	AC
Power supply	12V	24V	90÷240V
Power	15W	15W	15W
Max operating time	25 s	25 s	25 s
IEC34 service	50%	50%	50%
Protection class	IP66	IP66	IP66
Frequency	-	50/60 Hz	50/60 Hz

POWER CONNECTION DIAGRAM

- 1 Shared
- 2 Open
- 3 Closed

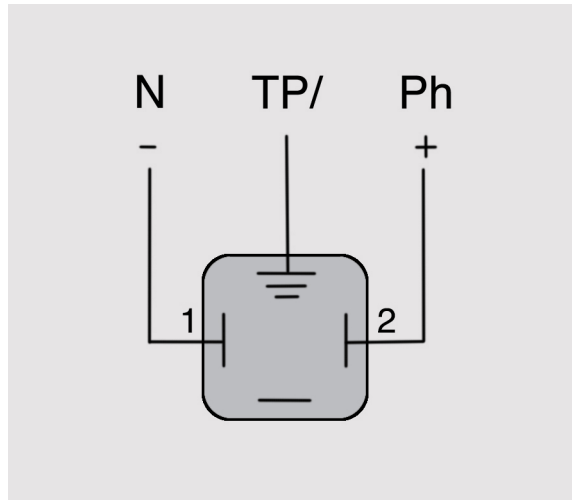

AUXILIARY LIMIT SWITCH CONNECTION DIAGRAM

- FC1 Open auxiliary limit switch
- FC2 Close auxiliary limit switch

- 4 Shared FC1
- 5 Open FC1
- 6 Shared FC2
- 7 Open FC2
- 8 Close FC1
- 9 Close FC2

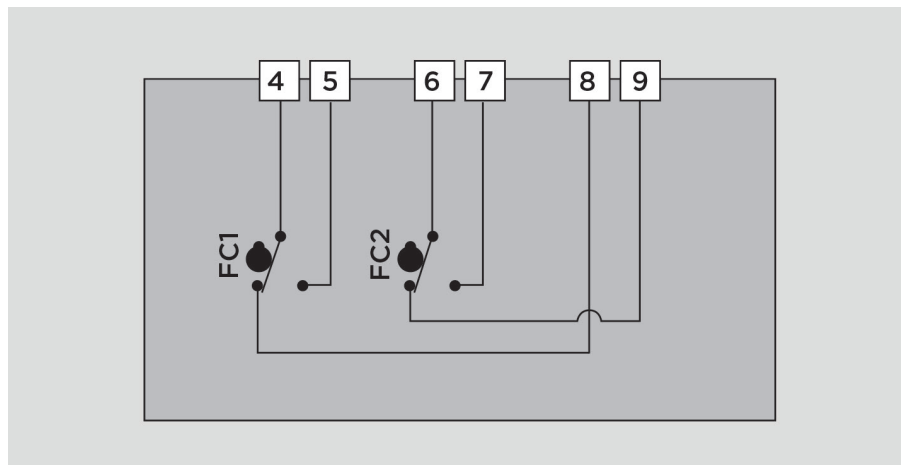

SIGNAL

13 Output +

14 Output -

15 Input -

16 Input +

D1 Error feedback

D2 Error feedback

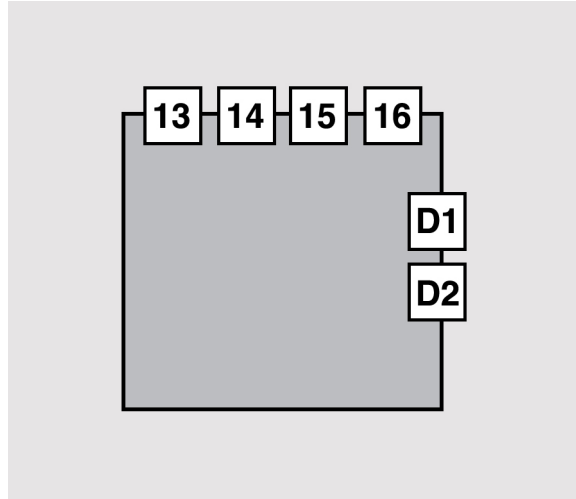

DIMENSIONS

VKR/CE DN 10÷50 PVC-U

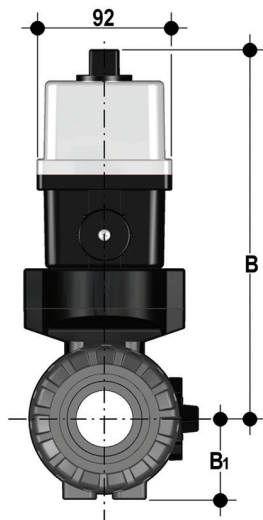

Dimensions common to all versions

DN	B	B ₁
10	205	29
15	205	29
20	216	34.5
25	221	39
32	238	46
40	244	52
50	261	62

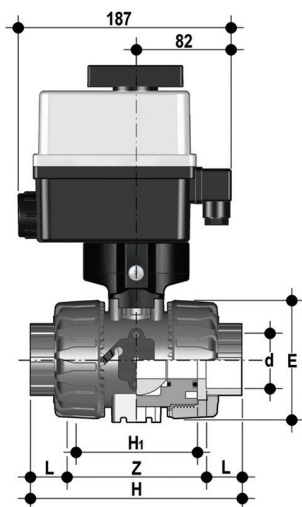

VKRIV/CE 90-240 V AC 4-20 mA

DUAL BLOCK® regulating ball valve with female metric ends with multi-volt electric modulating actuator 90-240 V AC 50-60 Hz

d	DN	PN	E	H	H ₁	L	Z	g	EPDM Code	FKM Code
16	10	16	54	103	65	14	75	1785	VKRIVEM016E0E	VKRIVEM016F0E
20	15	16	54	103	65	16	71	1775	VKRIVEM020E0E	VKRIVEM020F0E
25	20	16	65	115	70	19	77	1903	VKRIVEM025E0E	VKRIVEM025F0E
32	25	16	73	128	78	22	84	2011	VKRIVEM032E0E	VKRIVEM032F0E
40	32	16	86	146	88	26	94	2369	VKRIVEM040E0E	VKRIVEM040F0E
50	40	16	98	164	93	31	102	2601	VKRIVEM050E0E	VKRIVEM050F0E
63	50	*10	122	199	111	38	123	3218	VKRIVEM063E0E	VKRIVEM063F0E

* PN16 upon request

DIMENSIONS

VKR/CE DN 10÷50 PVC-U

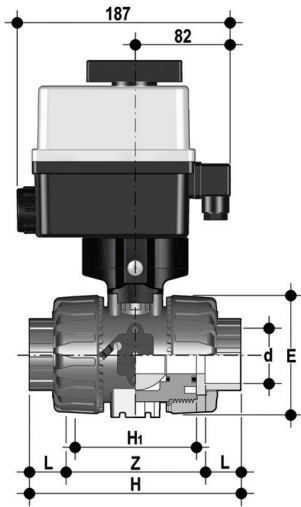

VKRIV/CE 24 V AC/DC 4-20 mA

DUAL BLOCK® regulating ball valve with female metric ends with electric modulating 24 V AC/DC

d	DN	PN	E	H	H ₁	L	Z	g	EPDM Code	FKM Code
16	10	16	54	103	65	14	75	1785	VKRIVEL016E0E	VKRIVEL016F0E
20	15	16	54	103	65	16	71	1775	VKRIVEL020E0E	VKRIVEL020F0E
25	20	16	65	115	70	19	77	1903	VKRIVEL025E0E	VKRIVEL025F0E
32	25	16	73	128	78	22	84	2011	VKRIVEL032E0E	VKRIVEL032F0E
40	32	16	86	146	88	26	94	2369	VKRIVEL040E0E	VKRIVEL040F0E
50	40	16	98	164	93	31	102	2601	VKRIVEL050E0E	VKRIVEL050F0E
63	50	*10	122	199	111	38	123	3218	VKRIVEL063E0E	VKRIVEL063F0E

* PN16 upon request

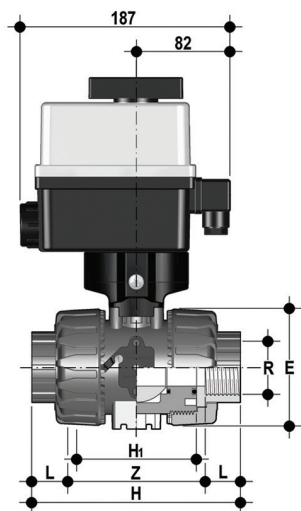

VKRFV/CE 90-240 V AC 4-20 mA

DUAL BLOCK® regulating ball valve with female ends, gas cylinder thread with multi-volt electric modulating actuator 90-240 V AC 50-60 Hz

R	DN	PN	E	H	H ₁	L	Z	g	EPDM Code	FKM Code
3/8"	10	16	54	103	65	12	80	1785	VKRFVEM038E0E	VKRFVEM038F0E
1/2"	15	16	54	110	65	15	80	1775	VKRFVEM012E0E	VKRFVEM012F0E
3/4"	20	16	65	116	70	16	83	1903	VKRFVEM034E0E	VKRFVEM034F0E
1"	25	16	73	134	78	19	96	2011	VKRFVEM100E0E	VKRFVEM100F0E
1" 1/4	32	16	86	153	88	21	110	2369	VKRFVEM114E0E	VKRFVEM114F0E
1" 1/2	40	16	98	156	93	21	113	2601	VKRFVEM112E0E	VKRFVEM112F0E
2"	50	*10	122	186	111	26	135	3218	VKRFVEM200E0E	VKRFVEM200F0E

* PN16 upon request

DIMENSIONS

VKR/CE DN 10÷50 PVC-U

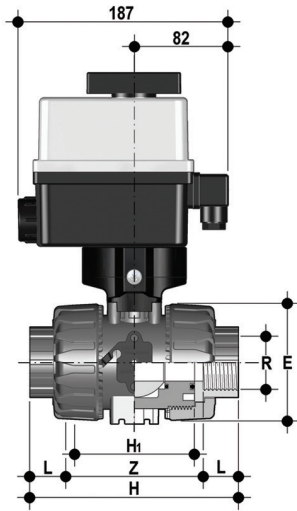

VKRFV/CE 24 V AC/DC 4-20 mA

DUAL BLOCK® regulating ball valve with female ends, gas cylinder thread with electric modulating actuator 24 V AC/DC

R	DN	PN	E	H	H ₁	L	Z	g	EPDM Code	FKM Code
3/8"	10	16	54	103	65	12	80	1785	VKRFVELO38E0E	VKRFVELO38F0E
1/2"	15	16	54	110	65	15	80	1775	VKRFVELO12E0E	VKRFVELO12F0E
3/4"	20	16	65	116	70	16	83	1903	VKRFVELO34E0E	VKRFVELO34F0E
1"	25	16	73	134	78	19	96	2011	VKRFVEL100E0E	VKRFVEL100F0E
1" 1/4	32	16	86	153	88	21	110	2369	VKRFVEL114E0E	VKRFVEL114F0E
1" 1/2	40	16	98	156	93	21	113	2601	VKRFVEL112E0E	VKRFVEL112F0E
2"	50	*10	122	186	111	26	135	3218	VKRFVEL200E0E	VKRFVEL200F0E

* PN16 upon request

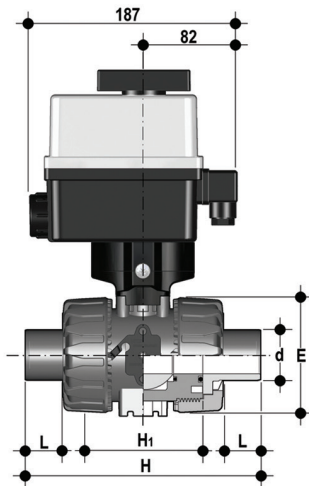

VKRDV/CE 90-240 V AC 4-20 mA

DUAL BLOCK® regulating ball valve with male ends, metric series with multi-volt electric modulating actuator 90-240 V AC 50-60 Hz

d	DN	PN	E	H	H ₁	L	Z	g	EPDM Code	FKM Code
16	10	16	54	149	65	14	80	1785	VKRDVEM016E0E	VKRDVEM016F0E
20	15	16	54	124	65	16	80	1775	VKRDVEM020E0E	VKRDVEM020F0E
25	20	16	65	144	70	19	83	1903	VKRDVEM025E0E	VKRDVEM025F0E
32	25	16	73	154	78	22	96	2011	VKRDVEM032E0E	VKRDVEM032F0E
40	32	16	86	174	88	26	110	2369	VKRDVEM040E0E	VKRDVEM040F0E
50	40	16	98	194	93	31	113	2601	VKRDVEM050E0E	VKRDVEM050F0E
63	50	*10	122	224	111	38	135	3218	VKRDVEM063E0E	VKRDVEM063F0E

* PN16 upon request

DIMENSIONS

VKR/CE DN 10÷50 PVC-U

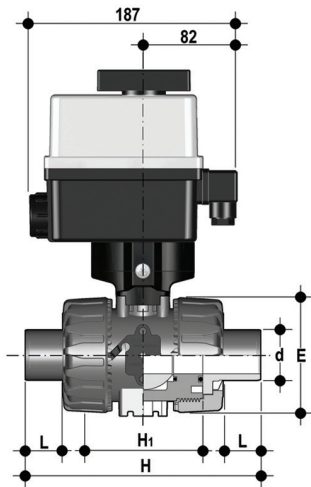

VKRDV/CE 24 V AC/DC 4-20 mA

DUAL BLOCK® regulating ball valve with male ends, metric series with electric modulating actuator 24 V AC/DC

d	DN	PN	E	H	H _i	L	g	EPDM Code	FKM Code
16	10	16	54	149	65	14	1785	VKRDVEL016E0E	VKRDVEL016F0E
20	15	16	54	124	65	16	1775	VKRDVEL020E0E	VKRDVEL020F0E
25	20	16	65	144	70	19	1903	VKRDVEL025E0E	VKRDVEL025F0E
32	25	16	73	154	78	22	2011	VKRDVEL032E0E	VKRDVEL032F0E
40	32	16	86	174	88	26	2369	VKRDVEL040E0E	VKRDVEL040F0E
50	40	16	98	194	93	31	2601	VKRDVEL050E0E	VKRDVEL050F0E
63	50	*10	122	224	111	38	3218	VKRDVEL063E0E	VKRDVEL063F0E

* PN16 upon request

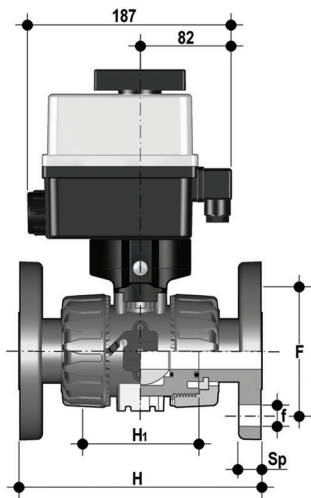

VKROV/CE 90-240 V AC 4-20 mA

DUAL BLOCK® regulating ball valve with fixed flanges, drilled EN/ISO/DIN PN10/16. Face to face according to EN 558-1 with multi-volt electric modulating actuator 90-240 V AC 50-60 Hz

d	DN	PN	H	H _i	F	f	U	Sp	g	EPDM Code	FKM Code
20	15	16	130	65	65	14	4	11	1775	VKROVEM020E0E	VKROVEM020F0E
25	20	16	150	70	75	14	4	14	1903	VKROVEM025E0E	VKROVEM025F0E
32	25	16	160	78	85	14	4	14	2011	VKROVEM032E0E	VKROVEM032F0E
40	32	16	180	88	100	18	4	14	2369	VKROVEM040E0E	VKROVEM040F0E
50	40	16	200	93	110	18	4	16	2601	VKROVEM050E0E	VKROVEM050F0E
63	50	*10	230	111	125	18	4	16	3218	VKROVEM063E0E	VKROVEM063F0E

* PN16 upon request

DIMENSIONS

VKR/CE DN 10÷50 PVC-U

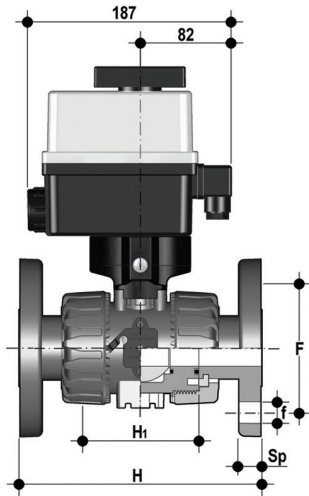

VKROV/CE 24 V AC/DC 4-20 mA

DUAL BLOCK® regulating ball valve with fixed flanges, drilled EN/ISO/DIN PN10/16. Face to face according to EN 558-1 with electric modulating 24 V AC/DC

d	DN	PN	H	H ₁	F	f	U	Sp	g	EPDM Code	FKM Code
20	15	16	130	65	65	14	4	11	1775	VKROVELO20E0E	VKROVELO20F0E
25	20	16	150	70	75	14	4	14	1903	VKROVELO25E0E	VKROVELO25F0E
32	25	16	160	78	85	14	4	14	2011	VKROVELO32E0E	VKROVELO32F0E
40	32	16	180	88	100	18	4	14	2369	VKROVELO40E0E	VKROVELO40F0E
50	40	16	200	93	110	18	4	16	2601	VKROVELO50E0E	VKROVELO50F0E
63	50	*10	230	111	125	18	4	16	3218	VKROVELO63E0E	VKROVELO63F0E

* PN16 upon request

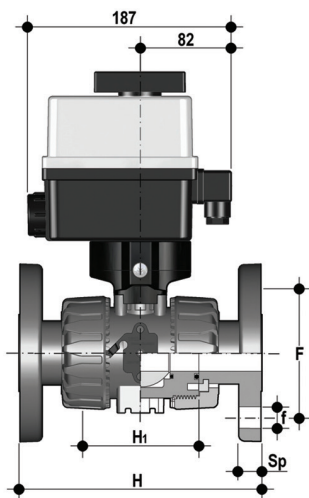

VKROAV/CE 90-240 V AC 4-20 mA

DUAL BLOCK® regulating ball valve with fixed flanges, drilled ANSI B16.5 cl.150#FF with multi-volt electric modulating actuator 90-240 V AC 50-60 Hz

d	DN	PN	H	H ₁	F	f	U	Sp	g	EPDM Code	FKM Code
1/2"	15	16	143	65	60.3	15.9	4	11	1775	VKROAVEM012E0E	VKROAVEM012F0E
3/4"	20	16	172	70	69.9	15.9	4	14	1903	VKROAVEM034E0E	VKROAVEM034F0E
1"	25	16	187	78	79.4	15.9	4	14	2011	VKROAVEM100E0E	VKROAVEM100F0E
1" 1/4	32	16	190	88	88.9	15.9	4	14	2369	VKROAVEM114E0E	VKROAVEM114F0E
1" 1/2	40	16	212	93	98.4	15.9	4	16	2601	VKROAVEM112E0E	VKROAVEM112F0E
2"	50	*10	234	111	120.7	19.1	4	16	3218	VKROAVEM200E0E	VKROAVEM200F0E

* PN16 upon request

DIMENSIONS

VKR/CE DN 10÷50 PVC-U

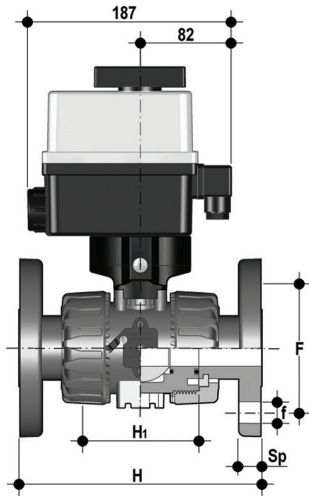

VKROAV/CE 24 V AC/DC 4-20 mA

DUAL BLOCK® regulating ball valve with fixed flanges, drilled ANSI B16.5 cl.150#FF with electric modulating 24 V AC/DC

d	DN	PN	H	H _i	F	f	U	Sp	g	EPDM Code	FKM Code
1/2"	15	16	143	65	60.3	15.9	4	11	1775	VKROAVEL012E0E	VKROAVEL012F0E
3/4"	20	16	172	70	69.9	15.9	4	14	1903	VKROAVEL034E0E	VKROAVEL034F0E
1"	25	16	187	78	79.4	15.9	4	14	2011	VKROAVEL100E0E	VKROAVEL100F0E
1" 1/4	32	16	190	88	88.9	15.9	4	14	2369	VKROAVEL114E0E	VKROAVEL114F0E
1" 1/2	40	16	212	93	98.4	15.9	4	16	2601	VKROAVEL112E0E	VKROAVEL112F0E
2"	50	*10	234	111	120.7	19.1	4	16	3218	VKROAVEL200E0E	VKROAVEL200F0E

* PN16 upon request

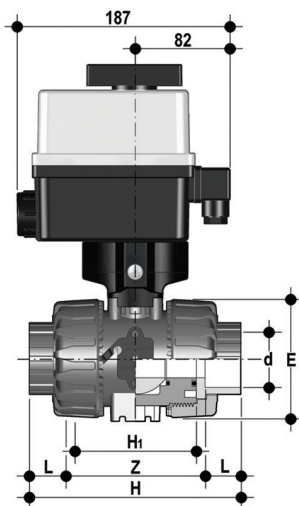

VKRLV/CE 90-240 V AC 4-20 mA

DUAL BLOCK® regulating ball valve with female ends for solvent welding, BS series with multi-volt electric modulating actuator 90-240 V AC 50-60 Hz

d	DN	PN	E	H	H _i	L	Z	g	EPDM Code	FKM Code
3/8"	10	16	54	103	65	14.5	74	1785	VKRLVEM038E0E	VKRLVEM038F0E
1/2"	15	16	54	103	65	16.5	70	1775	VKRLVEM012E0E	VKRLVEM012F0E
3/4"	20	16	65	115	70	19	77	1903	VKRLVEM034E0E	VKRLVEM034F0E
1"	25	16	73	128	78	22.5	83	2011	VKRLVEM100E0E	VKRLVEM100F0E
1" 1/4	32	16	86	146	88	26	94	2369	VKRLVEM114E0E	VKRLVEM114F0E
1" 1/2	40	16	98	164	93	30	104	2601	VKRLVEM112E0E	VKRLVEM112F0E
2"	50	*10	122	199	111	36	127	3218	VKRLVEM200E0E	VKRLVEM200F0E

* PN16 upon request

DIMENSIONS

VKR/CE DN 10÷50 PVC-U

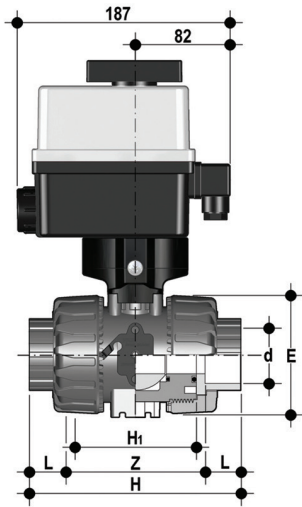

VKRLV/CE 24 V AC/DC 4-20 mA

DUAL BLOCK® regulating ball valve with female ends for solvent welding, BS series with electric modulating actuator 24 V AC/DC

d	DN	PN	E	H	H ₁	L	Z	g	EPDM Code	FKM Code
3/8"	10	16	54	103	65	14.5	74	1785	VKRLVEL038E0E	VKRLVEL038F0E
1/2"	15	16	54	103	65	16.5	70	1775	VKRLVEL012E0E	VKRLVEL012F0E
3/4"	20	16	65	115	70	19	77	1903	VKRLVEL034E0E	VKRLVEL034F0E
1"	25	16	73	128	78	22.5	83	2011	VKRLVEL100E0E	VKRLVEL100F0E
1" 1/4	32	16	86	146	88	26	94	2369	VKRLVEL114E0E	VKRLVEL114F0E
1" 1/2	40	16	98	164	93	30	104	2601	VKRLVEL112E0E	VKRLVEL112F0E
2"	50	*10	122	199	111	36	127	3218	VKRLVEL200E0E	VKRLVEL200F0E

* PN16 upon request

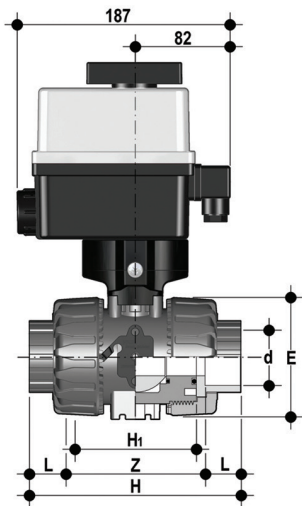

VKRAV/CE 90-240 V AC 4-20 mA

DUAL BLOCK® regulating ball valve with female ends for solvent welding, ASTM series with multi-volt electric modulating actuator 90-240 V AC 50-60 Hz

d	DN	PN	E	H	H ₁	L	Z	g	EPDM Code	FKM Code
3/8"	10	16	54	117	65	19.5	78	1785	VKRAVEM038E0E	VKRAVEM038F0E
1/2"	15	16	54	117	65	22.5	72	1775	VKRAVEM012E0E	VKRAVEM012F0E
3/4"	20	16	65	129	70	25.5	78	1903	VKRAVEM034E0E	VKRAVEM034F0E
1"	25	16	73	142	78	28.7	84.6	2011	VKRAVEM100E0E	VKRAVEM100F0E
1" 1/4	32	16	86	162	88	32	98	2369	VKRAVEM114E0E	VKRAVEM114F0E
1" 1/2	40	16	98	172	93	35	102	2601	VKRAVEM112E0E	VKRAVEM112F0E
2"	50	*10	122	199	111	38.2	122.6	3218	VKRAVEM200E0E	VKRAVEM200F0E

* PN16 upon request

DIMENSIONS

VKR/CE DN 10÷50 PVC-U

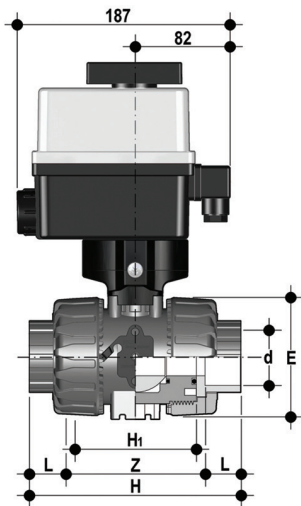

VKRAV/CE 24 V AC/DC 4-20 mA

DUAL BLOCK® regulating ball valve with female ends for solvent welding, ASTM series with electric modulating actuator 24 V AC/DC

d	DN	PN	E	H	H ₁	L	Z	g	EPDM Code	FKM Code
3/8"	10	16	54	117	65	19.5	78	1785	VKRAVEL038EOE	VKRAVEL038FOE
1/2"	15	16	54	117	65	22.5	72	1775	VKRAVEL012EOE	VKRAVEL012FOE
3/4"	20	16	65	129	70	25.5	78	1903	VKRAVEL034EOE	VKRAVEL034FOE
1"	25	16	73	142	78	28.7	84.6	2011	VKRAVEL100EOE	VKRAVEL100FOE
1" 1/4	32	16	86	162	88	32	98	2369	VKRAVEL114EOE	VKRAVEL114FOE
1" 1/2	40	16	98	172	93	35	102	2601	VKRAVEL112EOE	VKRAVEL112FOE
2"	50	*10	122	199	111	38.2	122.6	3218	VKRAVEL200EOE	VKRAVEL200FOE

* PN16 upon request

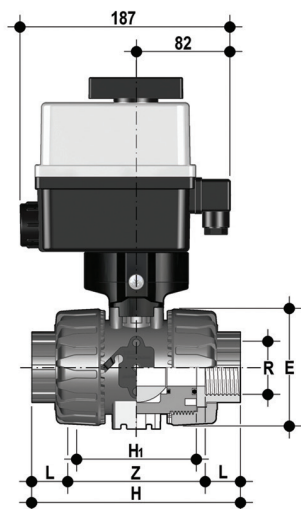

VKRVN/CE 90-240 V AC 4-20 mA

DUAL BLOCK® regulating ball valve with female ends, NPT thread with multi-volt electric modulating actuator 90-240 V AC 50-60 Hz

R	DN	PN	E	H	H ₁	L	Z	g	EPDM Code	FKM Code
3/8"	10	16	54	103	65	13.7	75.6	1785	VKRVNEM038EOE	VKRVNEM038FOE
1/2"	15	16	54	111	65	17.8	75.4	1775	VKRVNEM012EOE	VKRVNEM012FOE
3/4"	20	16	65	117	70	18	81	1903	VKRVNEM034EOE	VKRVNEM034FOE
1"	25	16	73	135	78	22.6	89.8	2011	VKRVNEM100EOE	VKRVNEM100FOE
1" 1/4	32	16	86	153	88	25.1	102.8	2369	VKRVNEM114EOE	VKRVNEM114FOE
1" 1/2	40	16	98	156	93	24.7	106.6	2601	VKRVNEM112EOE	VKRVNEM112FOE
2"	50	*10	122	186	111	29.6	126.8	3218	VKRVNEM200EOE	VKRVNEM200FOE

* PN16 upon request

DIMENSIONS

VKR/CE DN 10÷50 PVC-U

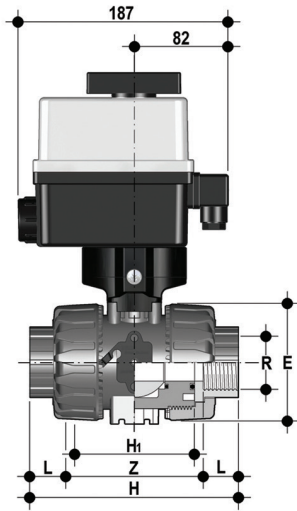

VKRN/CE 24 V AC/DC 4-20 mA

DUAL BLOCK® regulating ball valve with female ends, NPT thread with electric modulating actuator 24 V AC/DC

R	DN	PN	E	H	H _i	L	Z	g	EPDM Code	FKM Code
3/8"	10	16	54	103	65	13.7	75.6	1785	VKRNVELO38E0E	VKRNVELO38FOE
1/2"	15	16	54	111	65	17.8	75.4	1775	VKRNVELO12E0E	VKRNVELO12FOE
3/4"	20	16	65	117	70	18	81	1903	VKRNVELO34E0E	VKRNVELO34FOE
1"	25	16	73	135	78	22.6	89.8	2011	VKRNVEL100E0E	VKRNVEL100FOE
1" 1/4	32	16	86	153	88	25.1	102.8	2369	VKRNVEL114E0E	VKRNVEL114FOE
1" 1/2	40	16	98	156	93	24.7	106.6	2601	VKRNVEL112E0E	VKRNVEL112FOE
2"	50	*10	122	186	111	29.6	126.8	3218	VKRNVEL200E0E	VKRNVEL200FOE

* PN16 upon request

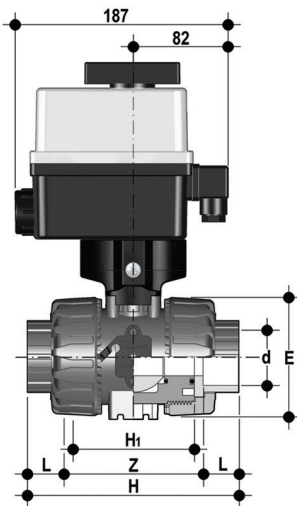

VKRJV/CE 90-240 V AC 4-20 mA

DUAL BLOCK® regulating ball valve with female ends for solvent welding, JIS series with multi-volt electric modulating actuator 90-240 V AC 50-60 Hz

d	DN	PN	E	H	H _i	L	Z	g	EPDM Code	FKM Code
1/2"	15	16	54	131	65	30	71	1775	VKRJVEM012E0E	VKRJVEM012FOE
3/4"	20	16	65	147	70	35	77	1903	VKRJVEM034E0E	VKRJVEM034FOE
1"	25	16	73	164	78	40	84	2011	VKRJVEM100E0E	VKRJVEM100FOE
1" 1/4	32	16	86	182	88	44	94	2369	VKRJVEM114E0E	VKRJVEM114FOE
1" 1/2	40	16	98	212	93	55	102	2601	VKRJVEM112E0E	VKRJVEM112FOE
2"	50	*10	122	248	111	63	122	3218	VKRJVEM200E0E	VKRJVEM200FOE

* PN16 upon request

DIMENSIONS

VKR/CE DN 10÷50 PVC-U

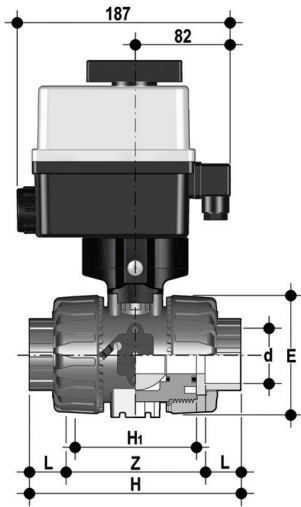

VKRJV/CE 24 V AC/DC 4-20 mA

DUAL BLOCK® regulating ball valve with female ends for solvent welding, JIS series with electric modulating actuator 24 V AC/DC

d	DN	PN	E	H	H _i	L	Z	g	EPDM Code	FKM Code
1/2"	15	16	54	131	65	30	71	1775	VKRJVEL012E0E	VKRJVEL012F0E
3/4"	20	16	65	147	70	35	77	1903	VKRJVEL034E0E	VKRJVEL034F0E
1"	25	16	73	164	78	40	84	2011	VKRJVEL100E0E	VKRJVEL100F0E
1" 1/4	32	16	86	182	88	44	94	2369	VKRJVEL114E0E	VKRJVEL114F0E
1" 1/2	40	16	98	212	93	55	102	2601	VKRJVEL112E0E	VKRJVEL112F0E
2"	50	*10	122	248	111	63	122	3218	VKRJVEL200E0E	VKRJVEL200F0E

* PN16 upon request

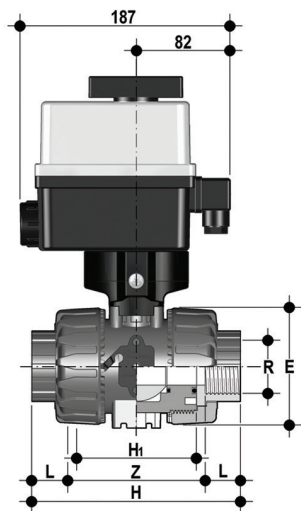

VKRGV/CE 90-240 V AC 4-20 mA

DUAL BLOCK® regulating ball valve with female ends, JIS thread with multi-volt electric modulating actuator 90-240 V AC 50-60 Hz

R	DN	PN	E	H	H _i	L	Z	g	EPDM Code	FKM Code
1/2"	15	16	54	103	65	16	71	1775	VKRGVEM012E0E	VKRGVEM012F0E
3/4"	20	16	65	115	70	19	77	1903	VKRGVEM034E0E	VKRGVEM034F0E
1"	25	16	73	128	78	22	84	2011	VKRGVEM100E0E	VKRGVEM100F0E
1" 1/4	32	16	86	146	88	25	96	2369	VKRGVEM114E0E	VKRGVEM114F0E
1" 1/2	40	16	98	164	93	26	112	2601	VKRGVEM112E0E	VKRGVEM112F0E
2"	50	*10	122	199	111	31	137	3218	VKRGVEM200E0E	VKRGVEM200F0E

* PN16 upon request

DIMENSIONS

VKR/CE DN 10÷50 PVC-U

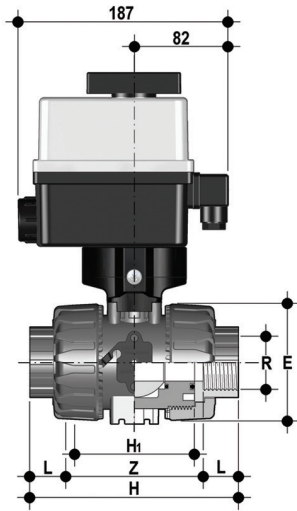

VKRGV/CE 24 V AC/DC 4-20 mA

DUAL BLOCK® regulating ball valve with female ends, JIS thread with electric modulating actuator 24 V AC/DC

R	DN	PN	E	H	H _i	L	Z	g	EPDM Code	FKM Code
1/2"	15	16	54	103	65	16	71	1775	VKRGVEL012E0E	VKRGVEL012F0E
3/4"	20	16	65	115	70	19	77	1903	VKRGVEL034E0E	VKRGVEL034F0E
1"	25	16	73	128	78	22	84	2011	VKRGVEL100E0E	VKRGVEL100F0E
1" 1/4	32	16	86	146	88	25	96	2369	VKRGVEL114E0E	VKRGVEL114F0E
1" 1/2	40	16	98	164	93	26	112	2601	VKRGVEL112E0E	VKRGVEL112F0E
2"	50	*10	122	199	111	31	137	3218	VKRGVEL200E0E	VKRGVEL200F0E

* PN16 upon request

DIMENSIONS

VKR/CE DN 10÷50 PP-H

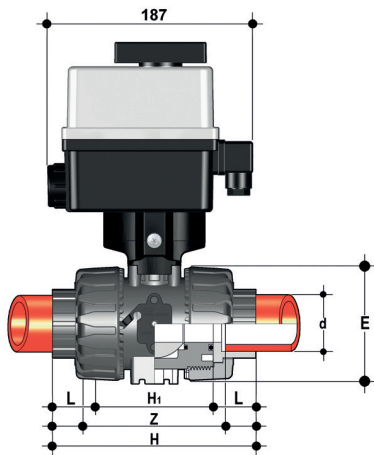

VKRIM/CE 90-240 V AC 4-20 mA

DUAL BLOCK® regulating ball valve with female ends for socket welding, metric series with multi-volt electric modulating actuator 90-240 V AC 50-60 Hz

d	DN	PN	E	H	H ₁	L	Z	g	EPDM Code	FKM Code
16	10	10	54	102	65	14	74.5	1720	VKRIMEM016E0E	VKRIMEM016F0E
20	15	10	54	102	65	15	73	1715	VKRIMEM020E0E	VKRIMEM020F0E
25	20	10	65	114	70	17	82	1791	VKRIMEM025E0E	VKRIMEM025F0E
32	25	10	73	126	78	19	90	1871	VKRIMEM032E0E	VKRIMEM032F0E
40	32	10	86	141	88	23	100	2156	VKRIMEM040E0E	VKRIMEM040F0E
50	40	10	98	164	93	24	117	2358	VKRIMEM050E0E	VKRIMEM050F0E
63	50	10	122	199	111	28	144	2807	VKRIMEM063E0E	VKRIMEM063F0E

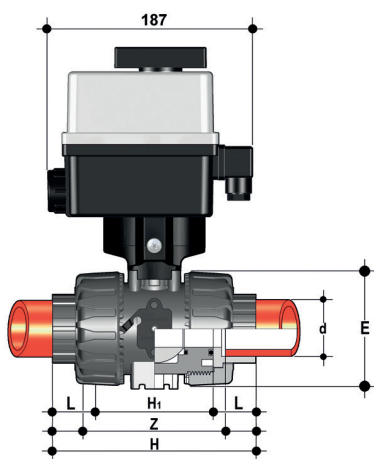

VKRIM/CE 24 V AC/DC 4-20 mA

DUAL BLOCK® regulating ball valve with female ends for socket welding, metric series with electric modulating actuator 24 V AC/DC, 12 V DC

d	DN	PN	E	H	H ₁	L	Z	g	EPDM Code	FKM Code
16	10	10	54	102	65	14	74.5	1720	VKRIMEL016E0E	VKRIMEL016F0E
20	15	10	54	102	65	15	73	1715	VKRIMEL020E0E	VKRIMEL020F0E
25	20	10	65	114	70	17	82	1791	VKRIMEL025E0E	VKRIMEL025F0E
32	25	10	73	126	78	19	90	1871	VKRIMEL032E0E	VKRIMEL032F0E
40	32	10	86	141	88	23	100	2156	VKRIMEL040E0E	VKRIMEL040F0E
50	40	10	98	164	93	24	117	2358	VKRIMEL050E0E	VKRIMEL050F0E
63	50	10	122	199	111	28	144	2807	VKRIMEL063E0E	VKRIMEL063F0E

DIMENSIONS

VKR/CE DN 10÷50 PP-H

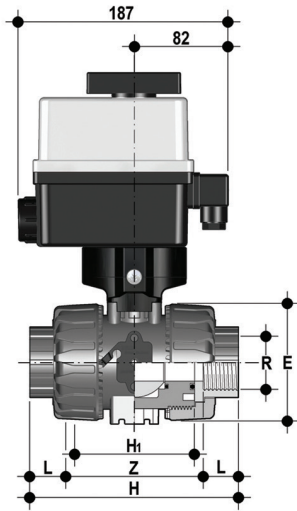

VKRFM/CE 90-240 V AC 4-20 mA

DUAL BLOCK® regulating ball valve with BSP thread female ends with multi-volt electric modulating actuator 90-240 V AC 50-60 Hz

R	DN	PN	E	H	H ₁	L	Z	g	EPDM Code	FKM Code
1/2"	15	10	54	110	65	16	83	1715	VKRFMEM012E0E	VKRFMEM012F0E
3/4"	20	10	65	116	70	19	96	1791	VKRFMEM034E0E	VKRFMEM034F0E
1"	25	10	73	134	78	21	110	1871	VKRFMEM100E0E	VKRFMEM100F0E
1" 1/4	32	10	86	153	88	21	113	2156	VKRFMEM114E0E	VKRFMEM114F0E
1" 1/2	40	10	98	156	93	26	135	2358	VKRFMEM112E0E	VKRFMEM112F0E
2"	50	10	122	186	111	26	135	2807	VKRFMEM200E0E	VKRFMEM200F0E

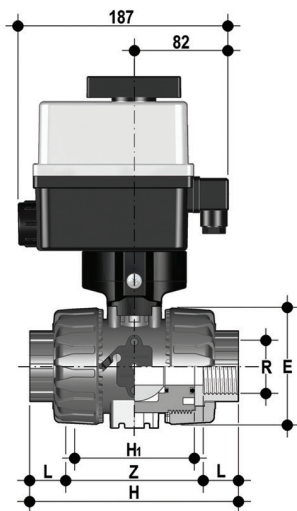

VKRFM/CE 24 V AC/DC 4-20 mA

DUAL BLOCK® regulating ball valve with BSP thread female ends with multi-volt electric modulating actuator 24 V AC/DC, 12 V DC

R	DN	PN	E	H	H ₁	L	Z	g	EPDM Code	FKM Code
1/2"	15	10	54	110	65	16	83	1715	VKRFMEL012E0E	VKRFMEL012F0E
3/4"	20	10	65	116	70	19	96	1791	VKRFMEL034E0E	VKRFMEL034F0E
1"	25	10	73	134	78	21	110	1871	VKRFMEL100E0E	VKRFMEL100F0E
1" 1/4	32	10	86	153	88	21	113	2156	VKRFMEL114E0E	VKRFMEL114F0E
1" 1/2	40	10	98	156	93	26	135	2358	VKRFMEL112E0E	VKRFMEL112F0E
2"	50	10	122	186	111	26	135	2807	VKRFMEL200E0E	VKRFMEL200F0E

DIMENSIONS

VKR/CE DN 10÷50 PP-H

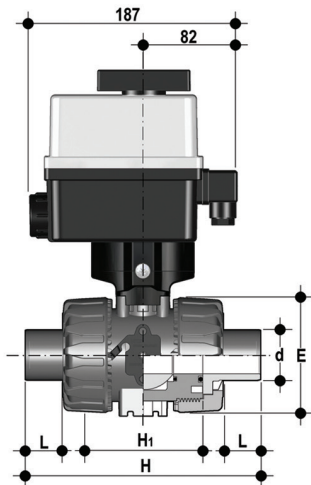

VKRDM/CE 90-240 V AC 4-20 mA

DUAL BLOCK® regulating ball valve with long spigot male ends in PP-H for head welding (CVDM) with multi-volt electric modulating actuator 90-240 V AC 50-60 Hz

d	DN	PN	E	H	H ₁	L	g	EPDM Code	FKM Code
20	15	10	54	124	65	16	1715	VKRDMEM020E0E	VKRDMEM020F0E
25	20	10	65	144	70	18	1791	VKRDMEM025E0E	VKRDMEM025F0E
32	25	10	73	154	78	20	1871	VKRDMEM032E0E	VKRDMEM032F0E
40	32	10	86	174	88	22	2156	VKRDMEM040E0E	VKRDMEM040F0E
50	40	10	98	194	93	23	2358	VKRDMEM050E0E	VKRDMEM050F0E
63	50	10	122	224	111	29	2807	VKRDMEM063E0E	VKRDMEM063F0E

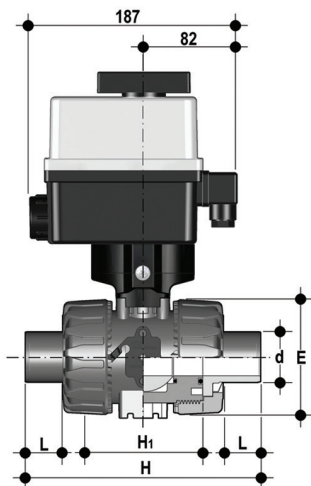

VKRDM/CE 24 V AC/DC 4-20 mA

DUAL BLOCK® regulating ball valve with long spigot male ends in PP-H for head welding (CVDM) with multi-volt electric modulating actuator 24 V AC/DC, 12 V DC

d	DN	PN	E	H	H ₁	L	g	EPDM Code	FKM Code
20	15	10	54	124	65	16	1715	VKRDMEL020E0E	VKRDMEL020F0E
25	20	10	65	144	70	18	1791	VKRDMEL025E0E	VKRDMEL025F0E
32	25	10	73	154	78	20	1871	VKRDMEL032E0E	VKRDMEL032F0E
40	32	10	86	174	88	22	2156	VKRDMEL040E0E	VKRDMEL040F0E
50	40	10	98	194	93	23	2358	VKRDMEL050E0E	VKRDMEL050F0E
63	50	10	122	224	111	29	2807	VKRDMEL063E0E	VKRDMEL063F0E

DIMENSIONS

VKR/CE DN 10÷50 PP-H

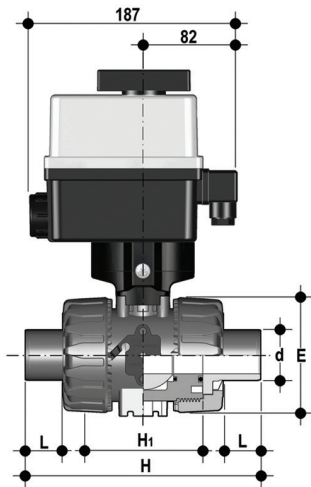

VKRBM/CE 90-240 V AC 4-20 mA

DUAL BLOCK® regulating ball valve with long spigot male ends in PP-H for head welding (CVDM) with multi-volt electric modulating actuator 90-240 V AC 50-60 Hz

d	DN	PN	E	H	Hi	L	Z	g	EPDM Code	FKM Code
20	15	10	54	175	65	41	93	1715	VKRBMEM020E0E	VKRBMEM020F0E
25	20	10	65	210	70	52	106	1791	VKRBMEM025E0E	VKRBMEM025F0E
32	25	10	73	226	78	55	116	1871	VKRBMEM032E0E	VKRBMEM032F0E
40	32	10	86	243	88	56	131	2156	VKRBMEM040E0E	VKRBMEM040F0E
50	40	10	98	261	93	58	145	2358	VKRBMEM050E0E	VKRBMEM050F0E
63	50	10	122	293	111	66	161	2807	VKRBMEM063E0E	VKRBMEM063F0E

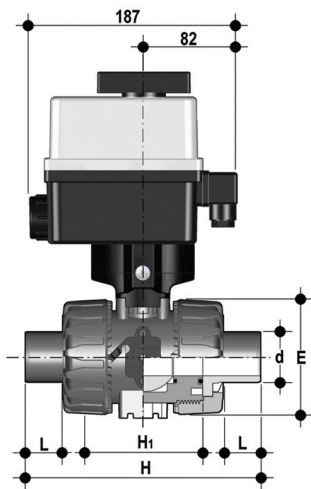

VKRBM/CE 24 V AC/DC 4-20 mA

DUAL BLOCK® regulating ball valve with long spigot male ends in PP-H for head welding (CVDM) with multi-volt electric modulating actuator 24 V AC/DC, 12 V DC

d	DN	PN	E	H	Hi	L	Z	g	EPDM Code	FKM Code
20	15	10	54	175	65	41	93	1715	VKRBMEL020E0E	VKRBMEL020F0E
25	20	10	65	210	70	52	106	1791	VKRBMEL025E0E	VKRBMEL025F0E
32	25	10	73	226	78	55	116	1871	VKRBMEL032E0E	VKRBMEL032F0E
40	32	10	86	243	88	56	131	2156	VKRBMEL040E0E	VKRBMEL040F0E
50	40	10	98	261	93	58	145	2358	VKRBMEL050E0E	VKRBMEL050F0E
63	50	10	122	293	111	66	161	2807	VKRBMEL063E0E	VKRBMEL063F0E

DIMENSIONS

VKR/CE DN 10÷50 PP-H

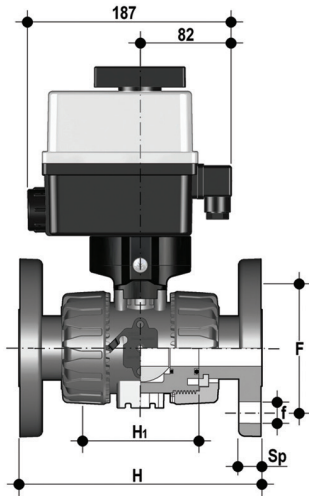

VKROM/CE 90-240 V AC 4-20 mA

DUAL BLOCK® regulating ball valve with fixed flanges, drilled EN/ISO/DIN PN10/16. Face to face according to EN 558-1. Multi-volt electric actuator 90-240 V AC 50-60 Hz

d	DN	PN	H	H ₁	F	f	U	Sp	g	EPDM Code	FKM Code
20	15	10	130	65	65	14	4	11	1715	VKROMEM020E0E	VKROMEM020F0E
25	20	10	150	70	75	14	4	14	1791	VKROMEM025E0E	VKROMEM025F0E
32	25	10	160	78	85	14	4	14	1871	VKROMEM032E0E	VKROMEM032F0E
40	32	10	180	88	100	18	4	14	2156	VKROMEM040E0E	VKROMEM040F0E
50	40	10	200	93	110	18	4	16	2358	VKROMEM050E0E	VKROMEM050F0E
63	50	10	230	111	125	18	4	16	2807	VKROMEM063E0E	VKROMEM063F0E

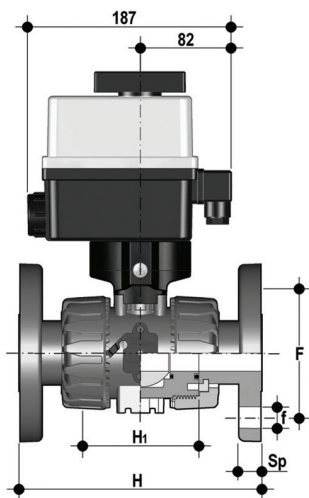

VKROM/CE 24 V AC/DC 4-20 mA

DUAL BLOCK® regulating ball valve with fixed flanges, drilled EN/ISO/DIN PN10/16. Face to face according to EN 558-1. 24 V AC/DC electric actuator

d	DN	PN	H	H ₁	F	f	U	Sp	g	EPDM Code	FKM Code
20	15	10	130	65	65	14	4	11	1715	VKROMEL020E0E	VKROMEL020F0E
25	20	10	150	70	75	14	4	14	1791	VKROMEL025E0E	VKROMEL025F0E
32	25	10	160	78	85	14	4	14	1871	VKROMEL032E0E	VKROMEL032F0E
40	32	10	180	88	100	18	4	14	2156	VKROMEL040E0E	VKROMEL040F0E
50	40	10	200	93	110	18	4	16	2358	VKROMEL050E0E	VKROMEL050F0E
63	50	10	230	111	125	18	4	16	2807	VKROMEL063E0E	VKROMEL063F0E

DIMENSIONS

VKR/CE DN 10÷50 PP-H

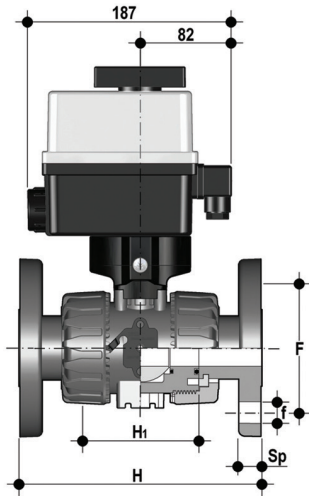

VKROAM/CE 90-240 V AC 4-20 mA

DUAL BLOCK® regulating ball valve with fixed flanges, drilled ANSI B16.5 cl.150#FF with multi-volt electric modulating actuator 24 V AC/DC, 12 V DC

d	DN	PN	H	H ₁	F	f	U	Sp	g	EPDM Code	FKM Code
1/2"	15	10	143	65	60.3	15.9	4	11	1715	VKROAMEM012E0E	VKROAMEM012F0E
3/4"	20	10	172	70	69.9	15.9	4	14	1791	VKROAMEM034E0E	VKROAMEM034F0E
1"	25	10	187	78	79.4	15.9	4	14	1871	VKROAMEM100E0E	VKROAMEM100F0E
1" 1/4	32	10	190	88	88.9	15.9	4	14	2156	VKROAMEM114E0E	VKROAMEM114F0E
1" 1/2	40	10	212	93	98.4	15.9	4	16	2358	VKROAMEM112E0E	VKROAMEM112F0E
2"	50	10	234	111	120.7	19.1	4	16	2807	VKROAMEM200E0E	VKROAMEM200F0E

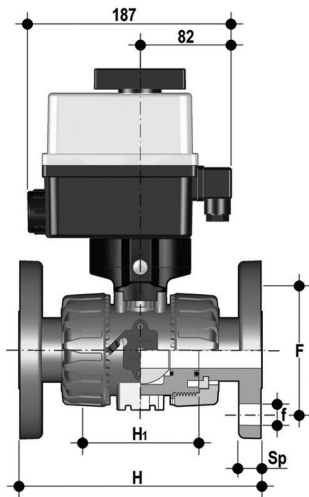

VKROAM/CE 24 V AC/DC 4-20 mA

DUAL BLOCK® regulating ball valve with fixed flanges, drilled ANSI B16.5 cl.150#FF with electric modulating actuator 24 V AC/DC, 12 V DC

d	DN	PN	H	H ₁	F	f	U	Sp	g	EPDM Code	FKM Code
1/2"	15	10	143	65	60.3	15.9	4	11	1715	VKROAMEL012E0E	VKROAMEL012F0E
3/4"	20	10	172	70	69.9	15.9	4	14	1791	VKROAMEL034E0E	VKROAMEL034F0E
1"	25	10	187	78	79.4	15.9	4	14	1871	VKROAMEL100E0E	VKROAMEL100F0E
1" 1/4	32	10	190	88	88.9	15.9	4	14	2156	VKROAMEL114E0E	VKROAMEL114F0E
1" 1/2	40	10	212	93	98.4	15.9	4	16	2358	VKROAMEL112E0E	VKROAMEL112F0E
2"	50	10	234	111	120.7	19.1	4	16	2807	VKROAMEL200E0E	VKROAMEL200F0E

DIMENSIONS

VKR/CE DN 10÷50 PVDF

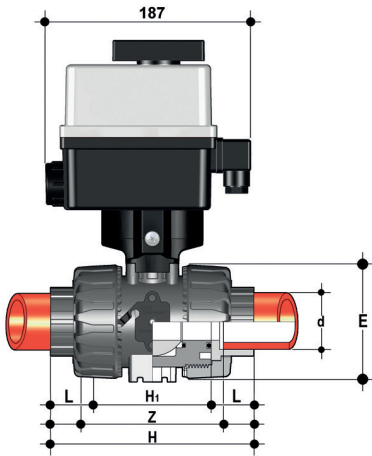

VKRIF/CE 90-240 V AC 4-20 mA

DUAL BLOCK® regulating ball valve with female ends for socket welding, metric series with multi-volt electric modulating actuator 90-240 V AC 50-60 Hz

d	DN	PN	E	H	H ₁	L	Z	g	FKM Code
16	10	16	54	102	65	14	74.5	1830	VKRIFEM016FOE
20	15	16	54	102	65	15	73	1825	VKRIFEM020FOE
25	20	16	65	114	70	17	82	1963	VKRIFEM025FOE
32	25	16	73	126	78	19	90	2123	VKRIFEM032FOE
40	32	16	86	141	88	23	100	2491	VKRIFEM040FOE
50	40	16	98	164	93	24	117	2826	VKRIFEM050FOE
63	50	*10	122	199	111	28	144	3611	VKRIFEM063FOE

* PN16 upon request

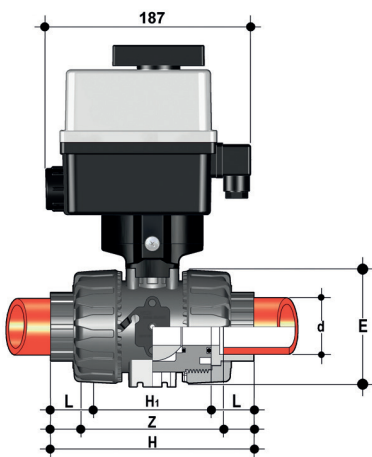

VKRIF/CE 24 V AC/DC 4-20 mA

DUAL BLOCK® regulating ball valve with female ends for socket welding, metric series with electric modulating actuator 24 V AC/DC, 12 V DC

d	DN	PN	E	H	H ₁	L	Z	g	FKM Code
16	10	16	54	102	65	14	74.5	1830	VKRIFEL016FOE
20	15	16	54	102	65	15	73	1825	VKRIFEL020FOE
25	20	16	65	114	70	17	82	1963	VKRIFEL025FOE
32	25	16	73	126	78	19	90	2123	VKRIFEL032FOE
40	32	16	86	141	88	23	100	2491	VKRIFEL040FOE
50	40	16	98	164	93	24	117	2826	VKRIFEL050FOE
63	50	*10	122	199	111	28	144	3611	VKRIFEL063FOE

* PN16 upon request

DIMENSIONS

VKR/CE DN 10÷50 PVDF

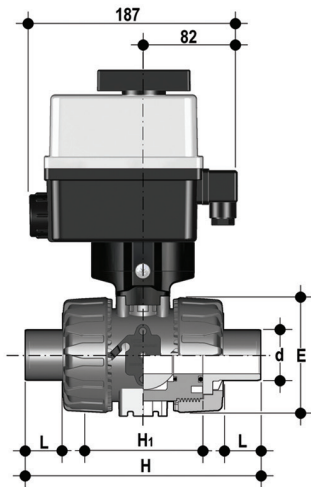

VKRDF/CE 90-240 V AC 4-20 mA

DUAL BLOCK® regulating ball valve with male ends for socket welding, metric series with multi-volt electric modulating actuator 90-240 V AC 50-60 Hz

d	DN	PN	E	H	H ₁	L	g	FKM Code
20	15	16	54	124	65	16	1825	VKRDFEM020FOE
25	20	16	65	144	70	18	1963	VKRDFEM025FOE
32	25	16	73	154	78	20	2123	VKRDFEM032FOE
40	32	16	86	174	88	22	2491	VKRDFEM040FOE
50	40	16	98	194	93	23	2826	VKRDFEM050FOE
63	50	*10	122	224	111	29	3611	VKRDFEM063FOE

* PN16 upon request

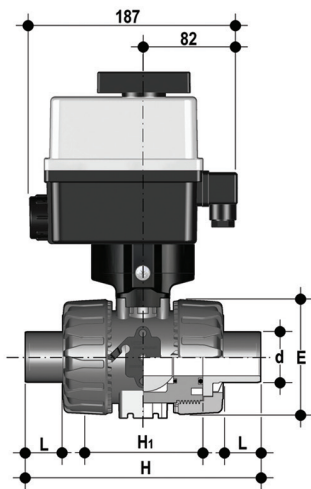

VKRDF/CE 24 V AC/DC 4-20 mA

DUAL BLOCK® regulating ball valve with male ends for socket welding, metric series with electric modulating actuator 24 V AC/DC, 12 V DC

d	DN	PN	E	H	H ₁	L	g	FKM Code
20	15	16	54	124	65	16	1825	VKRDFELO20FOE
25	20	16	65	144	70	18	1963	VKRDFELO25FOE
32	25	16	73	154	78	20	2123	VKRDFELO32FOE
40	32	16	86	174	88	22	2491	VKRDFELO40FOE
50	40	16	98	194	93	23	2826	VKRDFELO50FOE
63	50	*10	122	224	111	29	3611	VKRDFELO63FOE

* PN16 upon request

DIMENSIONS

VKR/CE DN 10÷50 PVDF

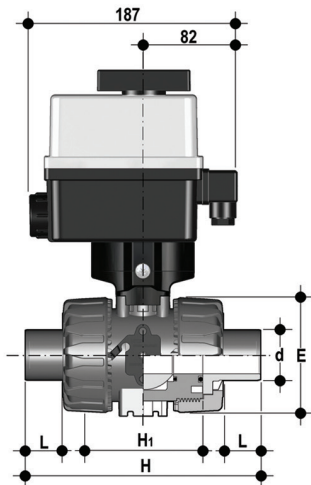

VKRBF/CE 90-240 V AC 4-20 mA

DUAL BLOCK® regulating ball valve with long spigot male ends in PVDF for head welding/IR (CVDF) with multi-volt electric modulating actuator 90-240 V AC 50-60 Hz

d	DN	PN	E	H	H ₁	L	Z	g	FKM Code
20	15	16	54	171	65	41	89	1825	VKRBFEM020FOE
25	20	16	65	204	70	52	100	1963	VKRBFEM025FOE
32	25	16	73	220	78	55	110	2123	VKRBFEM032FOE
40	32	16	86	238	88	56	126	2491	VKRBFEM040FOE
50	40	16	98	254	93	58	138	2826	VKRBFEM050FOE
63	50	*10	122	286	111	66	154	3611	VKRBFEM063FOE

* PN16 upon request

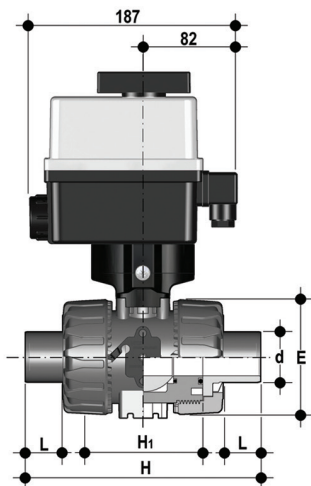

VKRBF/CE 24 V AC/DC 4-20 mA

DUAL BLOCK® regulating ball valve with long spigot male ends in PVDF for head welding/IR (CVDF) with multi-volt electric modulating actuator 24 V AC/DC, 12 V DC

d	DN	PN	E	H	H ₁	L	Z	g	FKM Code
20	15	16	54	171	65	41	89	1825	VKRBFEL020FOE
25	20	16	65	204	70	52	100	1963	VKRBFEL025FOE
32	25	16	73	220	78	55	110	2123	VKRBFEL032FOE
40	32	16	86	238	88	56	126	2491	VKRBFEL040FOE
50	40	16	98	254	93	58	138	2826	VKRBFEL050FOE
63	50	*10	122	286	111	66	154	3611	VKRBFEL063FOE

* PN16 upon request

DIMENSIONS

VKR/CE DN 10÷50 PVDF

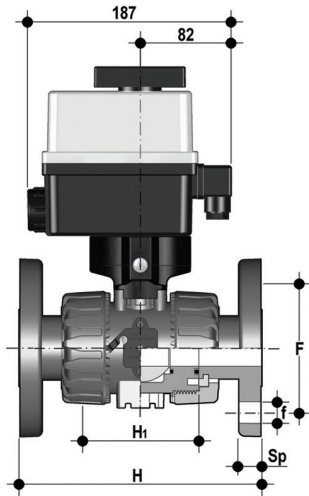

VKROF/CE 90-240 V AC 4-20 mA

DUAL BLOCK® regulating ball valve with fixed flanges, drilled EN/ISO/DIN PN10/16. Face to face according to EN 558-1. Multi-volt electric modulating actuator 90-240 V AC 50-60 Hz

d	DN	PN	H	H ₁	F	f	U	Sp	g	FKM Code
20	15	16	130	65	65	14	4	11	1825	VKROFEM020FOE
25	20	16	150	70	75	14	4	14	1963	VKROFEM025FOE
32	25	16	160	78	85	14	4	14	2123	VKROFEM032FOE
40	32	16	180	88	100	18	4	14	2491	VKROFEM040FOE
50	40	16	200	93	110	18	4	16	2826	VKROFEM050FOE
63	50	*10	230	111	125	18	4	16	3611	VKROFEM063FOE

* PN16 upon request

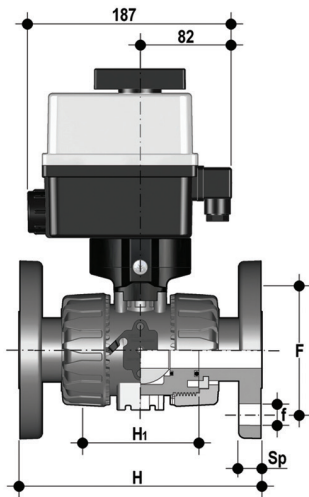

VKROF/CE 24 V AC/DC 4-20 mA

DUAL BLOCK® regulating ball valve with fixed flanges, drilled EN/ISO/DIN PN10/16. Face to face according to EN 558-1. 24 V AC/DC electric modulating actuator

d	DN	PN	H	H ₁	F	f	U	Sp	g	FKM Code
20	15	16	130	65	65	14	4	11	1825	VKROFEL020FOE
25	20	16	150	70	75	14	4	14	1963	VKROFEL025FOE
32	25	16	160	78	85	14	4	14	2123	VKROFEL032FOE
40	32	16	180	88	100	18	4	14	2491	VKROFEL040FOE
50	40	16	200	93	110	18	4	16	2826	VKROFEL050FOE
63	50	*10	230	111	125	18	4	16	3611	VKROFEL063FOE

* PN16 upon request

DIMENSIONS

VKR/CE DN 10÷50 PVDF

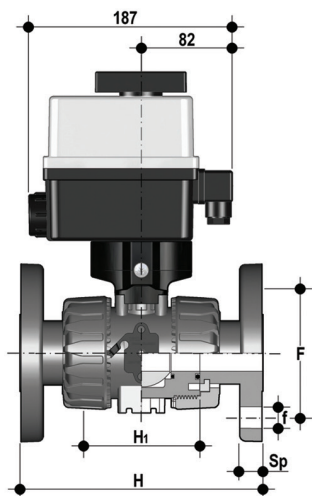

VKROAF/CE 90-240 V AC 4-20 mA

DUAL BLOCK® regulating ball valve with fixed flanges, drilled ANSI B16.5 cl.150#FF with multi-volt electric modulating actuator 24 V AC/DC, 12 V DC

d	DN	PN	H	H ₁	F	f	U	Sp	g	FKM Code
1/2"	15	16	143	65	60.3	15.9	4	11	1825	VKROAFEM012FOE
3/4"	20	16	172	70	69.9	15.9	4	14	1963	VKROAFEM034FOE
1"	25	16	187	78	79.4	15.9	4	14	2123	VKROAFEM100FOE
1" 1/4	32	16	190	88	88.9	15.9	4	14	2491	VKROAFEM114FOE
1" 1/2	40	16	212	93	98.4	15.9	4	16	2826	VKROAFEM112FOE
2"	50	*10	234	111	120.7	19.1	4	16	3611	VKROAFEM200FOE

* PN16 upon request

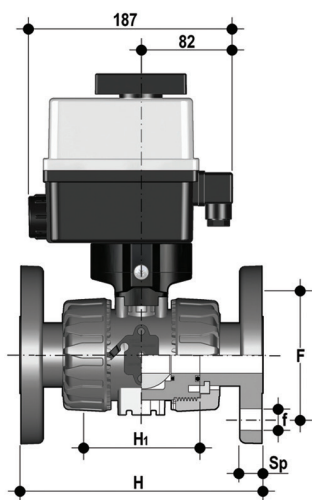

VKROAF/CE 24 V AC/DC 4-20 mA

DUAL BLOCK® regulating ball valve with fixed flanges, drilled ANSI B16.5 cl.150#FF with electric modulating actuator 24 V AC/DC, 12 V DC

d	DN	PN	H	H ₁	F	f	U	Sp	g	FKM Code
1/2"	15	16	143	65	60.3	15.9	4	11	1825	VKROAFEL012FOE
3/4"	20	16	172	70	69.9	15.9	4	14	1963	VKROAFEL034FOE
1"	25	16	187	78	79.4	15.9	4	14	2123	VKROAFEL100FOE
1" 1/4	32	16	190	88	88.9	15.9	4	14	2491	VKROAFEL114FOE
1" 1/2	40	16	212	93	98.4	15.9	4	16	2826	VKROAFEL112FOE
2"	50	*10	234	111	120.7	19.1	4	16	3611	VKROAFEL200FOE

* PN16 upon request

BRACKETS AND SUPPORTS



All valves, whether manual or actuated, must be adequately supported in many applications.

The VKR valve series is therefore set to be provided with threaded brackets (optional) that permit direct anchoring of the valve body without the need of other components.

For wall installation, dedicated PMKD mounting plates which are available as accessories can be used. These plates are to be fastened in place before the valve.

PMKD plates also allow VKR valve alignment with FIP ZIKM pipe clips as well as allowing different sizes of valves to be aligned.

d	DN	B	H	L	J*
16	10	31.5	27	20	M4 x 6
20	15	31.5	27	20	M4 x 6
25	20	40	30	20	M4 x 6
32	25	40	30	20	M4 x 6
40	32	50	35	30	M6 x 10
50	40	50	35	30	M6 x 10
63	50	60	40	30	M6 x 10

* With threaded inserts

COMPONENTS

EXPLODED VIEW

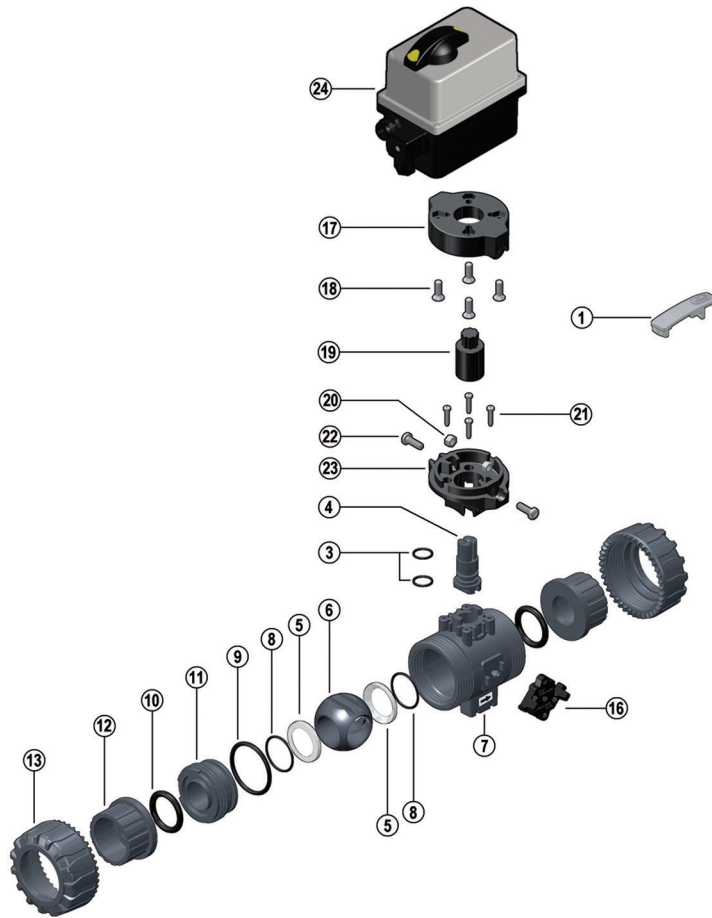

- | | | | | | |
|----------|--|-----------|---|-----------|--|
| 1 | Handle insert (PVC-U - 1) | 9 | Radial seal O-Ring (EPDM, FKM - 1)* | 17 | Upper plate (PP-GR - 1) |
| 3 | Stem seal (EPDM-FKM - 2)* | 10 | Socket seal O-Ring (EPDM-FKM - 2)* | 18 | Screw (STAINLESS steel - 4) |
| 4 | Stem (PVC-U / PP-H / PVDF - 1) | 11 | Ball seat carrier (PVC-U / PP-H / PVDF - 1) | 19 | Connection module (PP-GR/ stainless steel - 1) |
| 5 | Ball seal (PTFE - 2)* | 12 | End connector (PVC-U / PP-H / PVDF - 2)* | 20 | Nut (stainless steel - 2) |
| 6 | Patented ball design (PVC-U / PP-H / PVDF - 1) | 13 | Union nut (PVC-U / PP-H / PVDF - 2) | 21 | Screw (STAINLESS steel - 4) |
| 7 | Body (PVC-U / PP-H / PVDF - 1) | 16 | DUAL BLOCK® (POM - 1) | 22 | Screw (STAINLESS steel - 2) |
| 8 | Ball seal O-Rings (EPDM-FKM - 2)* | | | 23 | Lower plate (PP-GR - 1) |
| | | | | 24 | Electric actuator (PA6-Nylon - 1) |

* Spare parts

The material the component is made of and the quantity supplied are shown in brackets

DISASSEMBLY

- 1) Isolate the valve from the line (release the pressure and empty the pipeline).
- 2) Disconnect the actuator from the power mains.
- 3) Remove the two screws (22) and lift the actuator (24) with the upper plate (17).
- 4) Release the union nuts by pressing the lever on the DUAL BLOCK® (16) along the axis and separate it from the union nut (fig. 1). It is also possible to completely remove the locking device from the valve body.
- 5) Fully unscrew the union nuts (13) and extract the body sideways.
- 6) Before dismantling, hold the valve in a vertical position and open it 45° to drain any liquid that might remain.
- 7) After closing the valve, remove the special insert (1) and push the two projecting ends into the corresponding recesses on the ball seat carrier (11), turning counter-clockwise to extract it.
- 8) Press on the ball from the side opposite the "REGULAR - ADJUST" label, being sure not to scratch it, until the ball seat carrier exits (11), then extract the ball (6).
- 9) Extract the connection module (19) by pulling up.
- 10) Press the stem (4) inwards until it exits the body.
- 11) All the O-rings (3, 8, 9, 10) and PTFE ball seats (5) must be removed from their grooves, as shown in the exploded view.

ASSEMBLY

- 1) All the O-rings (3, 8, 9, 10) must be inserted in their grooves as shown in the exploded view.
- 2) Insert the stem (4) from inside the valve body (7).
- 3) Place the PTFE ball seats (5) in the housings in the body (7) and in the ball seat carrier (11).
- 4) Insert the ball (6) in the body as shown in fig. 2.
- 5) Screw the support (11) into the body and tighten up in the clockwise direction using the special insert (1) housed in the handle.
- 6) If previously removed, reassemble the DUAL BLOCK® system (16) on the valve body.
- 7) Insert the valve between the end connectors (12) making sure that they match the direction of flow shown by the arrow on the plate, then tighten the union nuts (13) making sure that the socket O-rings (10) do not come out of their grooves.
- 8) Insert the connection module (19) on the stem (4).
- 9) Reassemble the actuator (24) with plate (17) on the valve making sure the ball position (6) and actuator stem are aligned.
- 10) Tighten the two screws (22) and reconnect the actuator to the power supply.



All operations on equipment under pressure or containing compressed springs must be carried out under safe conditions for the operator.

Note: during mounting operations, it is advisable to lubricate the rubber seals. Mineral oils are not recommended for this task as they react aggressively with EPDM rubber.

The photos refer to the manual version and are purely exemplary.

Fig. 1



Fig. 2



INSTALLATION

Before proceeding with installation, please follow these instructions carefully:

- 1) Check that the pipes to be connected to the valve are aligned in order to avoid mechanical stress on the threaded joints.
 - 2) Check that the DUAL BLOCK® union nut locking device (16) is installed on the valve body.
 - 3) To release the union nuts (13), axially press the release lever to separate the lock and then unscrew it in the counter-clockwise direction.
 - 4) Unscrew the union nuts (13) and insert them on the pipe segments.
 - 5) Solvent weld or screw the end connectors (12) onto the pipe ends.
 - 6) Position the valve between the end connectors making sure that the direction of flow is the same as shown by the arrow on the plate. Hand tighten the union nuts (13) in the clockwise direction. Do not use a wrench or other tools which might damage the surface.
 - 7) Lock the union nuts by returning the DUAL BLOCK® to its housing, pressing on it until the hinges lock on the nuts.
 - 8) If necessary, support the pipework with FIP pipe clips or by means of the carrier built into the valve itself (see paragraph "fastening and supporting").
- Seals can be adjusted using the insert (1).

The seals can be adjusted later with the valve installed on the pipe by simply tightening the union nuts. This "micro adjustment", only possible with FIP valves thanks to the patented "Seat stop system", allows the seal to be recovered where PTFE ball seats are worn due to a high number of operations.

The Easytorque kit can also be used for micro adjustments (fig. 3).

Fig. 3



WARNINGS

- Always avoid sudden closing manoeuvres and protect the valve from accidental operations.