

 Aliaxis



D 90



CR DN 40÷300

PVC-U

Wafer check valve

CR DN 40÷300

The CR wafer check valve is designed to be installed directly between stubs and flanges in accordance with ISO/DIN standards.

WAFER CHECK VALVE

- Installed with FIP QPV (d50 - d160) stubs and QRV stubs using flat gasket QHV/Y (d225 - d315), on PVC piping class PN10 or lower with type ODV flanges
- **Metal support for easy and precise centring** of the valve during installation
- Can be installed in either a vertical or horizontal position
- **Sealing system with O-ring** for optimum sealing and installation without flat gaskets

Technical specifications	
Construction	Wafer check valve
Size range	DN 40 ÷ 300
Nominal pressure	5 bar with water at 20 °C
Temperature range	0 °C ÷ 60 °C
Coupling standards	Flanging system: DIN 2501 PN 10, EN ISO 1452, EN ISO 15493
Reference standards	Construction criteria: EN ISO 16137 EN ISO 1452, EN ISO 15493 Test methods and requirements: ISO 9393 Installation criteria: DVS 2204, DVS 2221, UNI 11242
Valve material	PVC-U
Seal material	EPDM

TECHNICAL DATA

PRESSURE VARIATION ACCORDING TO TEMPERATURE

For water e non-hazardous fluids with regard to which the material is classified as CHEMICALLY RESISTANT. In other cases, a reduction of the nominal pressure PN is required (25 years with safety factor).

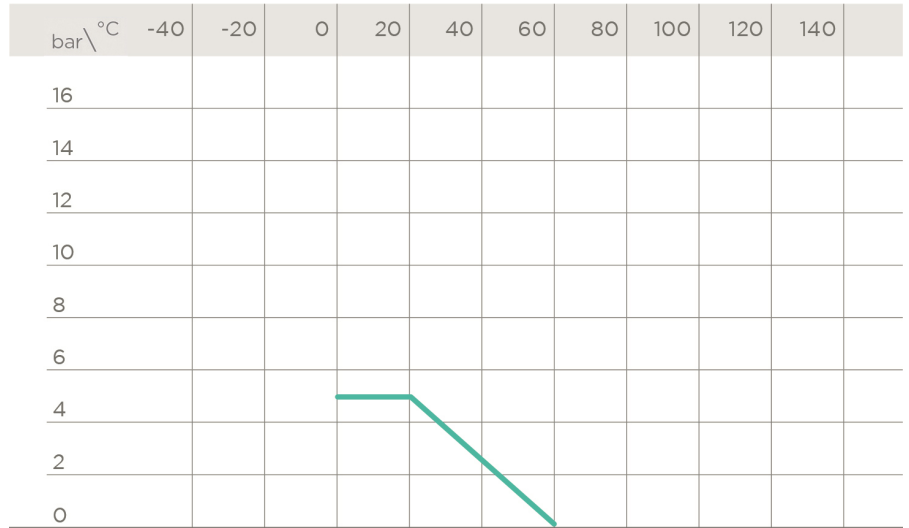

PRESSURE DROP GRAPH

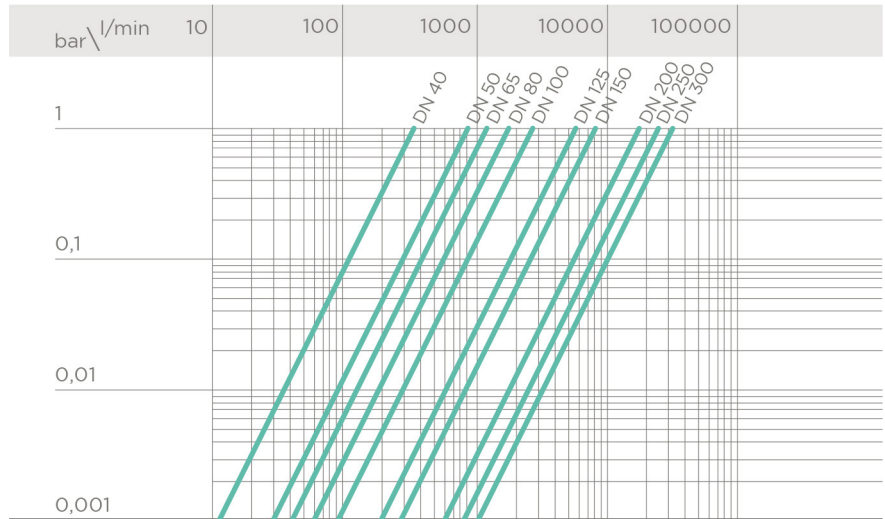

K_v100 FLOW COEFFICIENT

The K_v100 flow coefficient is the Q flow rate of litres per minute of water at a temperature of 20°C that will generate Δp= 1 bar pressure drop at a certain valve position. The K_v100 values shown in the table are calculated with the valve completely open.

DN	40	50	65	80	100	125	150	200	250	300
Kv100 l/min	370	900	1250	1867	2867	5700	8167	18800	25000	31900

MINIMUM PRESSURE REQUIRED TO OPEN THE VALVE IN A VERTICAL FLOW

DN	40	50	65	80	100	125	150	200	250	300
bar	0,002	0,003	0,003	0,003	0,003	0,003	0,005	0,005	0,008	0,008

MINIMUM VALVE SEALING PRESSURES

DN	40	50	65	80	100	125	150	200	250	300
bar	0,3	0,3	0,3	0,2	0,2	0,2	0,2	0,2	0,2	0,2

TIGHTENING TORQUE

DN	40	50	65	80	100	125	150	200	250	300
Nm*	8	10	10	10	0	15	20	38	45	50

*Tightening torques for nuts and bolts on couplings with backing rings. Values required to obtain the hydraulic test seal (1.5 x PN at 20°C) (new or lubricated nuts and bolts)

DIMENSIONS

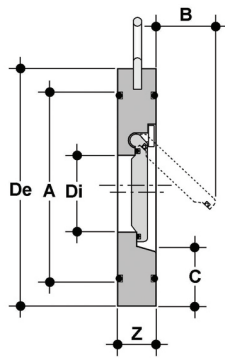

CROV

Wafer check valve in PVC-U/EPDM

d	DN	A	B	C	ISO/DIN	Di	OP	Z	g	*MOP (bar)	Code
50	40	72	25	28	95	22	0-5	16	160	6	CROV050E
63	50	86	37	29	109	32	0-5	20	260	6	CROV063E
75	65	105	50	31	129	40	0-5	20	330	6	CROV075E
90	80	119	61	32	144	54	0-5	20	400	6	CROV090E
110	100	146	77	31	164	70	0-5	22	560	6	CROV110E
140	125	173	94	35	195	92	0-5	23	760	6	CROV140E
160	150	197	100	40	220	105	0-5	25	1120	6	CROV160E
225	200	255	152	38	275	154	0-5	35	2130	6	CROV225E
280	250	312	180	41	330	192	0-5	40	3540	6	CROV280E
315	300	363	215	41	380	227	0-5	45	5350	6	CROV315E

INSTALLATION

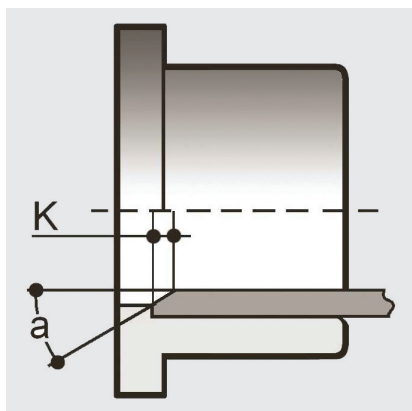

During installation, make sure that the following requirements are complied with:

- 1) Leave a straight section of pipe of length equal to 5 times the nominal diameter before and after the valve.
- 2) Do not install the valve directly on the pump flange. The use of flat gaskets is recommended in order to guarantee a perfect seal between the valve and stubs with serrated face.
- 3) Do not use pipes of thickness more than that of PN10 pipes.
- 4) The CR valve can be used on vertical pipes only if the fluid flow is upwards.
- 5) After having aligned the valve with the stub, tighten the flange bolts in a diagonal sequence to the required torque.

For sizes d110 and d160, in order to prevent impact between the disk and pipe, insert a spacer or chamfer the pipe itself as shown in fig.1 and indicated in the table.

d	Angle a for PN10 pipes	K (mm) for PN10 pipes
110	15°	5
160	30°	9